

559D/579D

KNUCKLEBOOM LOADERS



	559D	579D
Engine	Cat® C4.4 ACERT™ Tier 4 Final	Cat C4.4 ACERT Tier 4 Final
Gross Power @ 1,800 rpm	129.3 kW (173 hp)	129.3 kW (173 hp)
Standard Knuckleboom Reach to Pin	9.8 m (32 ft)	9.8 m (32 ft)
Operating Weight (less grapple)	15 331 kg (33,800 lb)	16 556 kg (36,500 lb)

More Production, Less Fuel Consumption

Reliable

A tried and true hydraulic system, engine install leveraging proven Cat components, and structures built to last provide unmatched reliability and durability.

Performance

Industry leading multi-function ability through a precisely tuned and field proven purpose built hydraulic system.

Comfortable

High capacity HVAC system and high back comfort seat with exceptional visibility keep the operator comfortable and productive.

Serviceability

Best in class ground level access to remote mounted filter banks provides convenience and safety while performing routine service.

Versatility

Excellent function speed, strong lift capacity, and impressive swing torque provide operating versatility – loading small stems in first thinnings, loading heavy, mature pine, or delimiting gnarly hardwoods.

Contents

Engine	4
Hydraulics	5
Operator Environment	6
Upper and Lower Structures	7
Front Linkages	8
Grapples	9
Delimiters	10
DS Package.....	11
Owning and Operating Costs	12
Serviceability	13
Safety	14
Customer Support.....	16
Sustainability	17
Specifications.....	18
Lift Charts	20
Standard Equipment.....	22
Other Equipment	23



For years, Cat® knuckleboom loaders have been known for superior hydraulic performance in tough logging applications, heavy-duty boom and structures that are built to last, and fuel efficient engines that provide impressive torque characteristics.

A complete factory installed delimitter slasher (DS) package ensures you have the right grapple, delimitter, and trailer combination for any job.

Engine

Power When You Need It



Proven Engine Technology

The Tier 4 Final Cat C4.4 ACERT™ engine boasts 129.5 kW (173 hp) and is equipped with a combination of proven electronic, fuel, air, and after treatment components. Applying these proven components and efficient technologies enables us to meet your high expectations for productivity, fuel and Diesel Exhaust Fluid (DEF) efficiency, reliability, and service life. The C4.4 engine meets U.S. EPA emissions standards.

Air Management

The Tier 4 engine features innovative air management systems that optimize airflow and enhance power, efficiency, and reliability. Twin, simple fixed, waste gated turbochargers allow maximum turbo performance to improve productivity, fuel efficiency, and long engine life, and to reduce operating costs.

Responsive

The high torque characteristics and impressive transient response performance make the C4.4 engine ideal for the duty cycles of heavy delimiting and loading applications.

Exceptional Cooling Capability

An oversized side-by-side engine coolant, hydraulic, and charge air cooling package with coarse fin spacing allows outside debris to pass through while efficiently dissipating heat. Individually isolated cooling cores eliminate core-to-core thermal stresses, increasing durability.

Speed Modulated Viscous Fan

A large 864 mm (34 in) diameter electronically controlled variable speed fan is modulated to provide cooling only as required, reducing noise levels and fuel consumption.

Diesel Exhaust Fluid

Cat engines equipped with a Selective Catalytic Reduction (SCR) system inject Diesel Exhaust Fluid (DEF) into the exhaust to reduce nitrogen oxide (NOx) emissions. DEF is a precise solution of high purity chemical grade urea and de-ionized water. The DEF used in Cat SCR systems must meet requirements of the International Organization for Standardization (ISO), requirements that are met by many brands of DEF, including those that carry AdBlue or API certifications.



Hydraulics

Continuous, Reliable, Responsive Control



Fast Response

The purpose-built negative flow hydraulic system forms the core of the D Series. A minimal amount of flow circulating through the valves at all times causes a partial stroke of the pump, providing quick responses to operator commands.

Reliability

Large diameter spools in valve sections allow for smoother movements due to stronger shift force capability, while providing higher tolerance to contamination particulate than competitive systems with smaller spool areas. The results are better performance and reduced downtime due to system contamination.

Controllability

The precisely tuned pilot control system provides joystick lever and foot pedal feedback to the user during dynamic operations to promote better machine feel during operation. This results in smoother movements and finer controllability.

Hydraulic Pump is Powerful, Responsive, and Quiet

Designed for continuous, efficient and reliable operation, the loader's dual in-line axial piston hydraulic pumps meet stringent requirements for noise, efficiency, controllability and durability.

Operating Modes

Within the main control display, three easy to select operating modes are available to meet fuel consumption and production requirements. Hydraulic flow is managed automatically and increases in each mode by adjusting the horsepower load on the engine. Consistent system pressure within each mode allows lift capacity and swing torque to remain equal regardless of mode selected.

1. Economy Mode
2. Run Mode
3. Power Mode

All operating modes provide superior multi-function ability, function response, control, and fast cycle times.

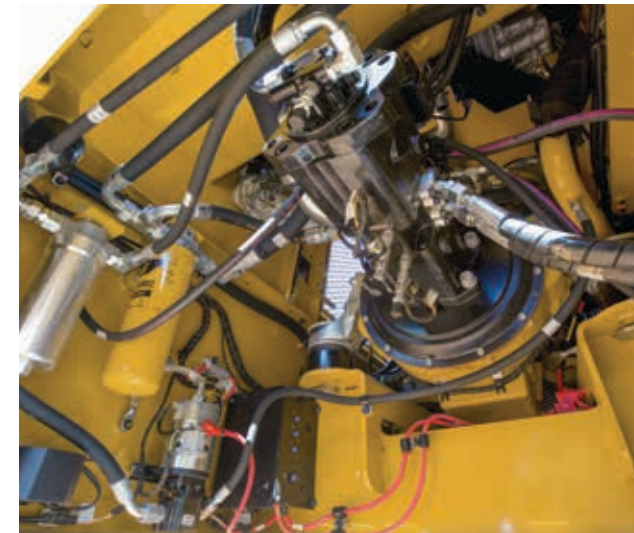

Operator Environment

Comfort and Convenience Keep Operator Productive



Visibility

The cab was strategically designed and built with loggers in mind. Best in class visibility is achieved with a full reverse slope front window that is easily kept clean with integral wiper for wet working conditions.

High Back Comfort Seat

The suspension seat features lumbar support and headrest for optimum comfort. Armrests are adjustable and cupped for better support.

Ergonomic Machine Controls

Hydraulic pilot actuated joystick controls and foot pedal swing enable precise operator control of all functions.

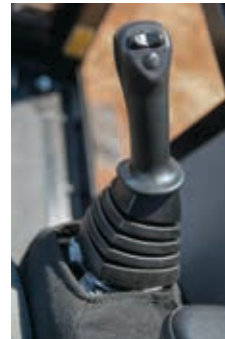

Climate Controlled Cab

An adjustable high capacity air conditioning system keeps the operator cool during the long, hot days of summer while the capable heating system will warm up the cab quickly on those cold winter mornings. Channeled air flow to louvered vents provide full coverage of the operator and also assists in defrosting/ defogging windows.

Quiet Cab

Sound dampening insulation throughout along with a quiet engine and hydraulic system provide best in class sound levels. Rubber cab mounts, designed to dampen transmitted energy to provide a comfortable ride.

Molded Consoles and Accessories

The molded console with storage trays eliminates clutter in the cab. Two 12-volt power ports and a factory installed CB mounting bracket, antenna cable, and power harness provide flexibility for additional electronic equipment.

Information Display

A new premium gauge cluster includes LED warning indicators and a digital display that provides information about machine operation, control activation, system diagnostics, and operator adjustable settings.

Satellite Radio and MP3 Ready

Satellite radio and an auxiliary audio port for MP3 players are standard.

Stabilizer Controls

Improved stabilizer controls enable equalization of stabilizer cylinder force, optimizing machine stability and providing uniform machine footing in varying ground conditions.



Upper and Lower Structures

Robust, Rugged Applications



Performance

High swing torque, swing speed, and lift capacity of Cat knuckleboom loaders reduce cycle times and lower cost per ton.

Durability

Robotic welding passes on both lower and upper frames deliver 3X better weld penetration and consistent quality.

Frames Built to Last

The rugged upper frame includes cross plate head-side reinforcements for severe delimiting applications while the lower frame includes a large bearing ring to support the swing bearing. Thick plating and reinforced joints provide rigidity throughout both frames.

Stabilizers

360 degree loader stability is achieved by wide stabilizer leg spread, large pad size, and deep below grade reach providing a stable base while cylinder mounted counter balance valves minimize cylinder movement.

Front Linkages

Designed for Heavy Lifting and Severe Delimiting



Durability

Reinforced fabricated booms feature optimized cross sections and strategically positioned internal plates in high stress areas. Front linkages are engineered to withstand years of heavy side-to-side delimiting and strenuous lifting applications.

Oversized Pins

Large diameter pins feature heavy-duty chrome for improved durability and excluder seals to retain grease and keep out contaminants.

Steel Tube Lines

Steel tube hydraulic lines secured to the main and stick boom provide extended life and effectively dissipate heat.

Boom Reach

Reach and lift with confidence with a boom reach of 32 feet on both the 559D and 579D.

Heel

Handling one log or multiple stems, heel them with either the Single "V" Extended or Double "VV" Extended Heel.

Cat® GLK Grapples

Work Tool Options to Meet Your Needs



High Tensile Steel

Grapple jaws are constructed of special high-tensile wear-resistant steel. Critical areas of the jaws are reinforced and designed to protect the cylinder rods and hoses.

Rounded Jaw Tips

Rounded jaw tips minimize damage to individual logs.

Heavy-Duty Rotators

Heavy-duty rotators include high-pressure swivels for demanding applications. Each head assembly is constructed of high-tensile steel with heavy-duty bearings and hardened gears.

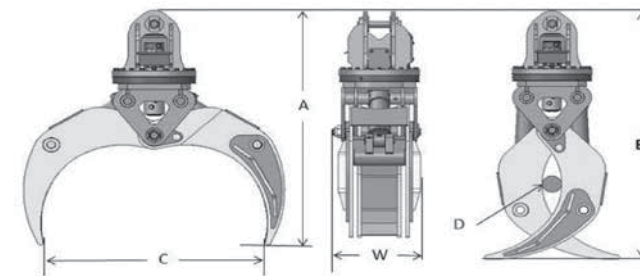

Swivel

A two-port and three-port swivel are available from the factory in both models and jaw configurations. The three-port swivel provides the versatility of adding a grapple saw.

Hold Valve

A cylinder mounted hold valve is standard in all models to improve log retention within jaws.

Reliability

Optimized Cat XT™-6 ToughGuard™ hose routings are designed to minimize loosening of fittings and improve hose life.

Heavy Duty Pins

Increased diameter cylinder pins and bushings reduce bearing stress by 25%.

Optimum Configurations

Cylinder size and jaw configuration provide holding forces for large multi-stem loads as well as the ability to handle single logs. From log loading to pull through delimiting, a selection of grapple styles are available, including:

- TW (tapered wedge) jaw designs for easily grabbing trees from a pile and aggressively gripping trees for delimiting.
- SN (straight, narrow) jaw designs for easy log handling in loading and millyard applications.

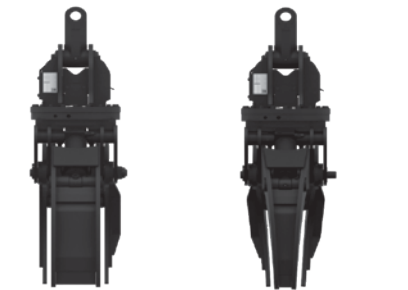

Straight Narrow (SN) Tapered Wedge (TW)

GLK Series Grapples				
Sales Model	Cat® GLK48	Cat GLK48	Cat GLK55	Cat GLK55
Jaw	TW	SN	TW	SN
Rotation (Continuous)	360 degrees	360 degrees	360 degrees	360 degrees
Operating Pressure (Rotation)	10340 kPa (1500 psi)	10340 kPa (1500 psi)	10340 kPa (1500 psi)	10340 kPa (1500 psi)
Oil Flow (Rotation)	54 L/min (14 US gpm)	54 L/min (14 US gpm)	54 L/min (14 US gpm)	54 L/min (14 US gpm)
Rotation Torque	1860 N·m (1371 lb ft)	1860 N·m (1371 lb ft)	1860 N·m (1371 lb ft)	1860 N·m (1371 lb ft)
Operating Pressure (Open/Close)	24980 kPa (3625 psi)	24980 kPa (3625 psi)	24980 kPa (3625 psi)	24980 kPa (3625 psi)
Weight (Including hoses to boom)	845 kg (1862 lb)	865 kg (1908 lb)	867 kg (1912 lb)	888 kg (1957 lb)
Width (W)	567 mm (22.3 in)	567 mm (22.3 in)	567 mm (22.3 in)	567 mm (22.3 in)
Height (A) (Open Tongs)	1684 mm (66.3 in)	1685 mm (66.3 in)	1724 mm (67.9 in)	1726 mm (68.0 in)
Height (B) (Closed Tongs)	1843 mm (72.5 in)	1844 mm (72.6 in)	1908 mm (75.1 in)	1910 mm (75.2 in)
Maximum Opening (C)	1210 mm (47.6 in)	1216 mm (47.9 in)	1380 mm (54.3 in)	1386 mm (54.6 in)
Minimum Opening (D)	112.3 mm (4.5 in)	112.3 mm (4.5 in)	127 mm (5.0 in)	127 mm (5.0 in)

Note: All specifications are approximate

Cat® DLK Delimber

Developed to Handle Tough Jobs

High Capacity

A large throat opening and round tubular log guides on the front allow for rapid loading. A rear log guide assists in grouping stems together and keeping them retained in the main throat.

Performance

Dual edged sharpened knife blades allow for efficient pull or push delimiting and cleaner stems.

Auto Chain Tensioning System

The 44-inch topping saw features an auto chain tensioning system. It increases production and extends bar and chain life while minimizing service and maintenance. The system includes a chain de-tensioning tool for safe, easy chain removal.

Durability

Larger diameter knife pins reduce bearing stress by 12 percent.

Easy to Service

A central lubrication bank, ground access to level bar and chain oil reservoir, and single tool cradle roller adjustment ensure easy, safe daily maintenance.



Delimber Right

Delimber Rear

Cat® DLK426 Delimber	
Weight	3402 kg (7500 lb)
Throat Opening	87.31 cm (34.38 in)
Nose Roller	53.34 cm (21 in) Wide 40.64 cm (16 in) Diameter
Number of Knives	4
Alloy Steel Blades	35.56 cm (14 in)
Topping Saw Motor	208.2 (55)
Roller Tip Saw Bar	111.76 cm (44 in) 465-3975
Auto Chain Tensioning System	Standard
Bar and Chain Oiler	Automatic
Bar and Chain Oil Reservoir Capacity	31.23 L (8.25 US gal)
Saw Chain	Pitch 1.9 cm (0.75 in) Drive Links 66
Direct Saw Drive	Drive Sprocket 9.93 cm (3.94 in, Case hardened) 9 teeth
Turntable Bearing Diameter	55.88 cm (22 in)
Turntable Mounting Bolts	1.9 cm (0.75 in) Grade 8
Frame Dimensions	Length 184.02 cm (72.45 in) Width 218.82 cm (86.15 in) Height 244.23 cm (96.10 in)
Mounting Base	H-D Rotating Cradle with 7.62 cm (3 in) Diameter pins

Note: All specifications are approximate

Delimber/Slasher Package

A Complete Factory Installed System



The Delimber/Slasher (DS) package is a complete factory installed timber merchandising system consisting of a knuckleboom loader and grapple, trailer with trailer-mounted delimeter, and ground saw slasher connections. The structural design of these loaders is proven to provide long life in punishing, pull-through delimiting applications.

The package contains a four-knife DLK426 pull-through delimeter to match application requirements. These delimiters are designed to allow quick, easy loading of trees and produce clean, delimited stems in a flash.

The delimiters have central lubrication banks and ground level oil fill for quick, easy service. An automatic chain tensioner simplifies maintenance and extends bar and chain life.

The delimiting trailers are built with structural reinforcing in critical areas for durability. Non-suspension or crawler style suspension are available. This feature allows the operator to quickly set up the loader in a proper operating position and make adjustments to maintain a stable base under the delimeter.

All trailers feature hydraulically adjustable landing gear that is adjustable from in-cab controls.

Owning and Operating Costs

Proven Best Investment



More Productive

The new Cat D Series features advanced controls to manage pump and engine interface to optimize performance and fuel efficiency. You can move more wood and lower your cost per ton.

Fuel Efficient

A choice of operating modes give you the flexibility to match hydraulic power to the job. For normal loading operations, the Economy Mode provides fast cycle times and the most fuel-efficient performance.

Designed for Logging Applications

The booms and base structures are specifically designed for loading and delimiting applications, providing the strength and durability that allow for a long service life.

Product Link™

Standard equipment on D Series knucklebooms, Product Link™ allows tracking of operational parameters to ensure optimum utilization and on-time service intervals.

Automatic Idle Down

The loader control system includes an automatic engine idle down feature to reduce fuel consumption during periods of inactivity.

Service Free Aftertreatment

No service is required of the C4.4 engine Selective Catalytic Reduction (SCR) emission system.

Serviceability

Easy to Service and Maintain



Ground Level Filter Access

Easy changing of engine, fuel, pilot, and case drain filters.



Hydraulic Oil Electric Fill Pump

A sight gauge makes it easy to know when hydraulic oil needs to be added. Adding hydraulic oil has never been easier with a standard on-board service hose and electric fill pump. Hydraulic oil is pumped through the filtering system and into the tank, maintaining cleanliness and reducing the possibility for system contamination.

Outer-Tank Capsule Filter Assembly

Eliminates contamination backflow during filter changes.

Eco-Valves

Allows capturing of fluids for easy draining without spills.



Electric Fuel Priming Pump

Easy priming of the fuel system after a service interval, eliminating the potential of fuel contamination.

Swivel, Collector, and Swing Motor Access

Large access openings provide easy serviceability of fittings and connectors. Oil level check is accessed on the platform.

Isolated Cooling Cores

Isolated cooling cores can be individually removed, reducing service times.

Single Main Boom Lift Cylinder

An oversized single main boom lift cylinder provides ample lift capacity and reduces the number of cylinders to service.

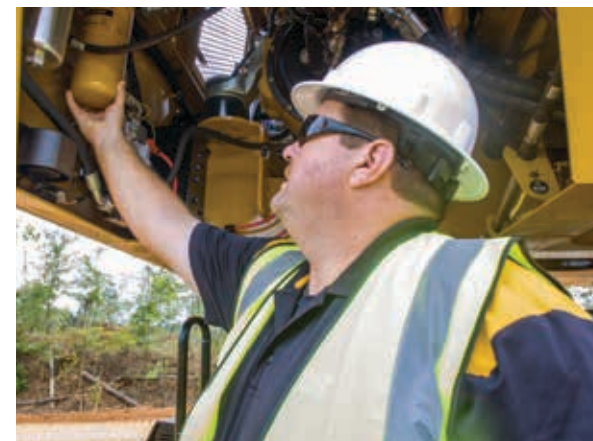

Safety

Integrated Safety Features



Access

A robust and integrated step system with two handrails ensures safe access to platform.

Front Window Guard

Heavy-duty swing out front window guarding provides an extra level of protection while handling large tree-length logs and stacking high wood piles.

Stabilizer Movement Alarm

An integrated alarm alerts bystanders of stabilizer movement

Pilot Enable Alarm

Integrated pilot enable alarm alerts bystanders when pilot function is engaged.

Grapple Hold Valves

Standard grapple hold valves improve log retention while handling heavy loads.

Anti-Skid Plates

Walk on the upper and lower frame with confidence with anti-skid plating surfaces to reduce slipping hazards.

Boom Lowering Valve

A standard manual boom lowering valve is on the main valve section in the event the main boom needs to be lowered during an engine shutdown condition.



Customer Support

Ready to Help. Anytime. Anywhere.



Caterpillar is known the world over for the quality of customer support from its dealer network – the industry’s best. No matter where you are, the expertise of a Cat dealer is always nearby. Your local Cat dealer is your forestry consultant who can recommend the machines, work tools and services to maximize your operation and provide the support to keep you at top productivity.

- 24-hour parts availability, where and when you need them, to minimize expensive downtime.
- Remanufactured parts that carry the same warranty as new parts at a reduced cost.
- Operator training to get the most out of your Cat equipment.
- Field services to provide on-site help when needed.
- Timely repair and replacement services.
- Customer Support Agreements to lower your operating costs.
- State-of-the-art diagnostic programs, such as S-O-SSM oil analysis, inspection services and trend reporting to help avoid unscheduled repairs.
- Financing programs for buying, renting or leasing Cat equipment.
- Cat Access Account, a fast and convenient way to pay for or rent anything offered at any Cat dealer or The Cat Rental Store.
- Cat Insurance to cover equipment losses from theft, collision, flood, upset or overturn, fire, vandalism and more.
- Product LinkTM to manage your equipment fleet through remote monitoring.
- Cat Certified Rebuild to get a second life from your equipment.

For more information on Cat products, dealer services and industry solutions, visit us at www.cat.com.

Sustainability Reducing Environmental Impacts

Structures

Major structures and components are built to be rebuilt, reducing waste and replacement costs.

ACERTTM Engines

The Tier 4 Final C4.4 ACERTTM engine, along with the Cat Clean Emissions Module (CEM), meets U.S. EPA Tier 4 Final emissions standards.

Eco-Valves

Allows capturing of fluids for easy draining without spillage.

Efficient

Three different operating modes, including an eco mode allow the operator to tailor the machines performance to application needs, helping to increase fuel efficiency.

559D/579D Knuckleboom Loader Specifications

Engine

559D		
Engine Model	Cat C4.4 ACERT™	
Gross Power @ 1,800 rpm	129.3 kW	173 hp

579D		
Engine Model	Cat C4.4 ACERT	
Gross Power @ 1,800 rpm	129.3 kW	173 hp

Weights

559D		
Operating Weight without grapple	15 331 kg	33,800 lb
Counterweight	0 kg	0 lb

579D		
Operating Weight without grapple	16 556 kg	36,500 lb
Counterweight	653 kg	1,440 lb

Hydraulic System

559D		
Hydraulic Oil Flow @ 1,800 rpm	230/174 lpm	60/46 gpm
Hydraulic Pressure – System	24 994 kPa	3,625 psi
Hydraulic Pressure – Swing	24 994 kPa	3,625 psi
Cylinders – Main	one	
Cylinders – Stick	one	
Cylinders – Stabilizers	four	

579D		
Hydraulic Oil Flow @ 1,800 rpm	230/230 lpm	60/60 gpm
Hydraulic Pressure – System	24 994 kPa	3,625 psi
Hydraulic Pressure – Swing	24 994 kPa	3,625 psi
Cylinders – Main	one	
Cylinders – Stick	one	
Cylinders – Stabilizers	four	

Operating Specifications

559D		
Maximum Reach	9.8 m	32.0 ft
Swing Torque	66 870 N·m	49,173 lbf·ft
Swing Speed	11 rpm	
Tailswing	2692 mm	106 in
Swing Bearing Diameter (ball path)	1105 mm	43.5 in

579D		
Maximum Reach	9.8 m	32.0 ft
Swing Torque	100 360 N·m	73,800 lbf·ft
Swing Speed	9.5 rpm	
Tailswing	2750 mm	108.2 in
Swing Bearing Diameter (ball path)	1105 mm	43.5 in

*Theoretical
** All specifications are approximate

Service Refill Capacities

559D		
Fuel Tank	378 L	100 gal
Hydraulic Tank	302 L	80 gal
Engine Oil	8 L	2.1 gal
Cooling System	29 L	7.5 gal
Swing Drive	4 L	1.0 gal
DEF Tank	19 L	5 gal

579D		
Fuel Tank	378 L	100 gal
Hydraulic Tank	302 L	80 gal
Engine Oil	8 L	2.1 gal
Cooling System	29 L	7.5 gal
Swing Drive	4 L	1.0 gal
DEF Tank	19 L	5 gal

Dimensions

559D		
Height to Top of Cab	4041 mm	159.1 in
Stabilizer Spread at Grade	4758 mm	187.3 in
Stabilizer Spread at Maximum Down Reach	4237 mm	166.8 in
Stabilizer Reach Below Grade	433 mm	17 in
Stabilizer Pad Size	508 x 711 mm	20 x 28 in

579D		
Height to Top of Cab	4041 mm	159.1 in
Stabilizer Spread at Grade	4758 mm	187.3 in
Stabilizer Spread at Maximum Down Reach	4237 mm	166.8 in
Stabilizer Reach Below Grade	433 mm	17 in
Stabilizer Pad Size	508 x 711 mm	20 x 28 in

* All dimensions are on suspension trailer.

Standards

559D	OFPS	cab meets SAE J2267
579D	OFPS	cab meets SAE J2267

Shipping Dimensions (mounted trailer)

559D	Width	2573 mm	101.3 in
	Height	4003 mm	157.6 in
579D	Width	2573 mm	101.3 in
	Height	4041 mm	159.1 in

559D/579D Knuckleboom Loader Specifications

Dimensions

All dimensions are approximate.

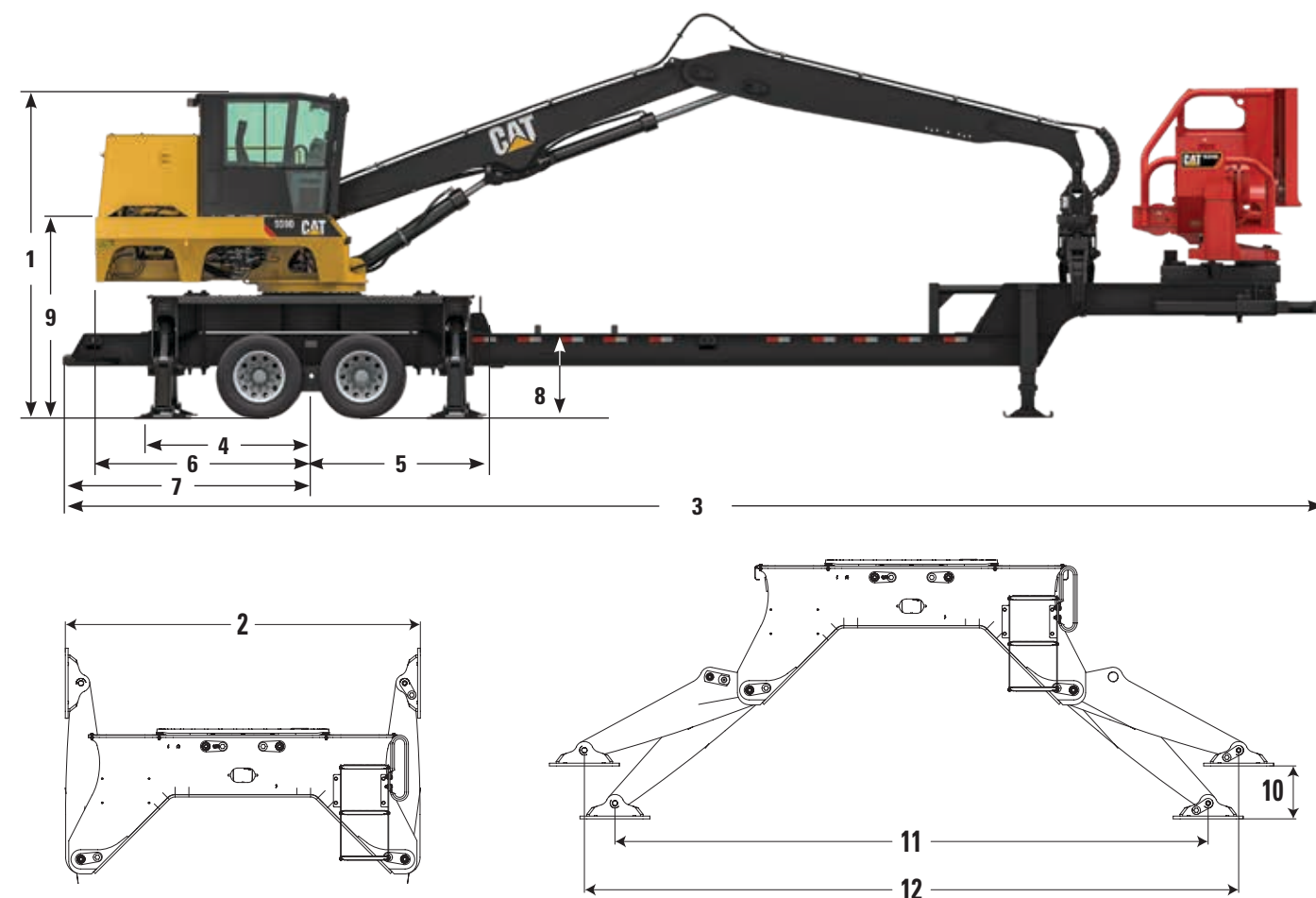

	559D		579D	
1 Height – to Top of Cab	4041 mm	159.1 in	4041 mm	159.1 in
2 Width – in Transport Position	2573 mm	101.3 in	2573 mm	101.3 in
3 Length – Trailer Option	15.88 m	52.1 ft	15.88 m	52.1 ft
4 Distance – Center of Rotate to Rear Subframe	2039 mm	80.3 in	2039 mm	80.3 in
5 Distance – Center of Rotate to Front Stabilizer Pad	2185 mm	86.0 in	2185 mm	86.0 in
6 Distance – Center of Rotate to Rear of Loader	2692 mm	106.0 in	2750 mm	108.2 in
7 Distance – Center of Rotate to Rear of Trailer Option	3124 mm	123.0 in	3124 mm	123.0 in
8 Height – to Trailer Deck	1029 mm	40.5 in	1029 mm	40.5 in
9 Height – to Main Boom Pin	2522 mm	99.3 in	2522 mm	99.3 in
10 Stabilizer Reach Below Grade	433 mm	17.0 in	433 mm	17.0 in
11 Stabilizer Spread – to Pin Center at Maximum Down Reach	4237 mm	166.8 in	4237 mm	166.8 in
12 Stabilizer Spread – to Pin Center at Grade	4758 mm	187.3 in	4758 mm	187.3 in

* All dimensions are on suspension trailer.

559D/579D Knuckleboom Loader Specifications

559D Lift Chart

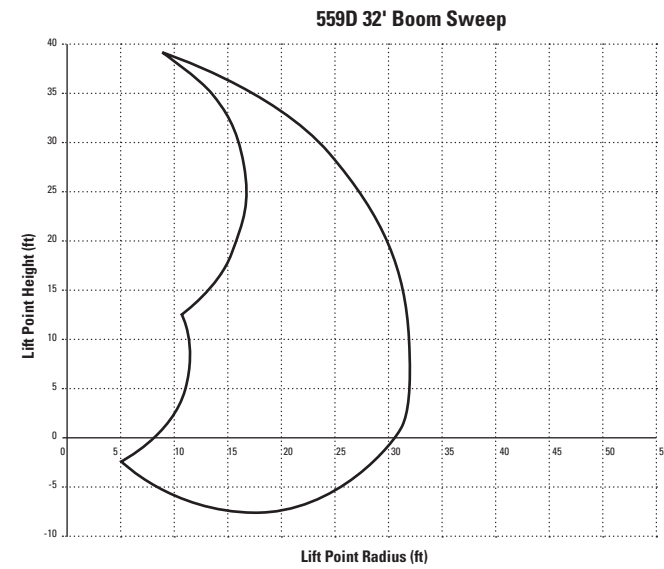

Height	3 m (10 ft)		4.6 m (15 ft)		6.1 m (20 ft)		7.6 m (25 ft)		9.1 m (30 ft)		Maximum Reach		
	kg	lb	kg	lb	kg	lb	kg	lb	kg	lb	kg	lb	
10.6 m (35 ft)			6586	14,519									100% Hydraulics Over End Over Side
			5729	12,631									
			5729	12,631									
9.1 m (30 ft)					6222	13,717							100% Hydraulics Over End Over Side
					5413	11,934							
					5413	11,934							
7.6 m (25 ft)					6606	14,564	5555	12,246					100% Hydraulics Over End Over Side
					5747	12,671	4833	10,654					
					5747	12,671	4833	10,654					
6.1 m (20 ft)					6770	14,925	6116	13,483					100% Hydraulics Over End Over Side
					5889	12,984	5321	11,730					
					5889	12,984	5273	11,625*					
4.6 m (15 ft)			8462	18,655	7247	15,977	6300	13,889	5099	11,242			100% Hydraulics Over End Over Side
			7362	16,230	6305	13,900	5481	12,084	4436	9,780			
			7362	16,230	6305	13,900	5182	11,425*	3707	8,172*			
3 m (10 ft)			9997	22,039	8176	18,025	6809	15,011	5444	12,002	3967	8,746	100% Hydraulics Over End Over Side
			8697	19,174	7113	15,682	5924	13,060	4736	10,442	3542	7,809	
			8697	19,174	7113	15,682	5041	11,114*	3653	8,053*	3275	7,220*	
1.5 m (5 ft)			11 524	25,407	8700	19,181	6942	15,305	5270	11,618	4026	8,875	100% Hydraulics Over End Over Side
			10 026	22,104	7569	16,687	6040	13,315	4585	10,108	3502	7,721	
			10 026	22,104	7244	15,971*	4889	10,778*	3590	7,915*	3242	7,147*	
0 m (0 ft)	10 359	22,837	11 889	26,210	8755	19,302	6729	14,835	4720	10,406			100% Hydraulics Over End Over Side
	9012	19,868	10 343	22,803	7617	16,792	5854	12,906	4107	9,054			
	9012	19,868	10 343	22,803	6982	15,393*	4766	10,508*	3550	7,826*			
-1.5 m (-5 ft)	9843	21,700	10 932	24,101	8008	17,655	5849	12,895					100% Hydraulics Over End Over Side
	8563	18,879	9511	20,968	6967	15,360	5089	11,219					
	8563	18,879	9511	20,968	6840	15,079*	4709	10,381*					

*Stability limited capacities.

559D/579D Knuckleboom Loader Specifications

579D Lift Chart

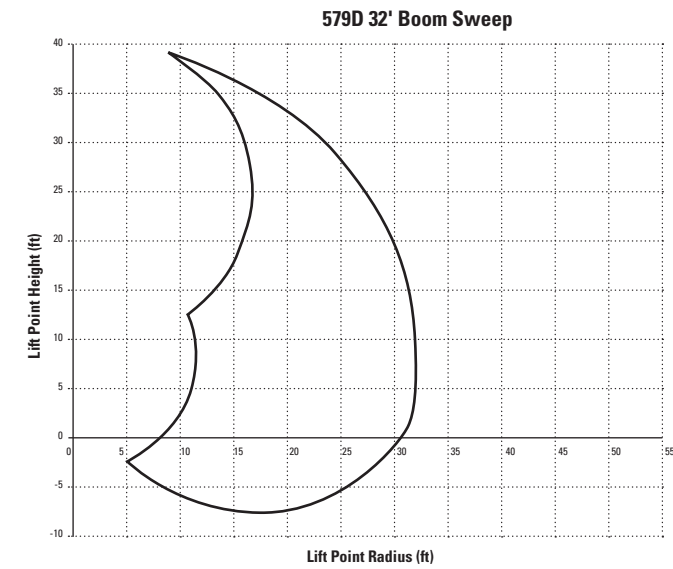

Height	3 m (10 ft)		4.6 m (15 ft)		6.1 m (20 ft)		7.6 m (25 ft)		9.1 m (30 ft)		Maximum Reach		
	kg	lb	kg	lb	kg	lb	kg	lb	kg	lb	kg	lb	
10.6 m (35 ft)			7555	16,656									100% Hydraulics Over End Over Side
			6573	14,490									
			6573	14,490									
9.1 m (30 ft)					7142	15,746							100% Hydraulics Over End Over Side
					6214	13,699							
					6214	13,699							
7.6 m (25 ft)					7855	17,318	6385	14,076					100% Hydraulics Over End Over Side
					6834	15,067	5555	12,246					
					6834	15,067	5555	12,246					
6.1 m (20 ft)					8053	17,754	7314	16,125					100% Hydraulics Over End Over Side
					7006	15,446	6,363	14,029					
					7006	15,446	5,893	12,992*					
4.6 m (15 ft)			9995	22,035	8621	19,007	7539	16,620	5868	12,937			100% Hydraulics Over End Over Side
			8695	19,170	7501	16,536	6559	14,460	5105	11,255			
			8695	19,170	7501	16,536	5798	12,782*	4173	9,199*			
3 m (10 ft)			11 705	25,806	9743	21,479	8148	17,964	6555	14,452	4583	10,103	100% Hydraulics Over End Over Side
			10 184	22,452	8476	18,687	7089	15,628	5703	12,573	3987	8,790	
			10 184	22,452	8442	18,612*	5649	12,455*	4117	9,076*	3699	8,156*	
1.5 m (5 ft)			13 708	30,222	10 385	22,896	8320	18,342	6358	14,018	4649	10,249	100% Hydraulics Over End Over Side
			11 926	26,293	9035	19,919	7238	15,957	5532	12,196	4045	8,917	
			11 926	26,293	8100	17,857*	5490	12,103*	4051	8,931*	3665	8,080*	
0 m (0 ft)	12 902	28,444	14 178	31,258	10 473	23,090	8083	17,821	5670	12,501			100% Hydraulics Over End Over Side
	11 225	24,746	12 335	27,195	9112	20,089	7032	15,504	4933	10,876			
	11 225	24,746	12 335	27,195	7825	17,251*	5361	11,820*	4009	8,838*			
-1.5 m (-5 ft)	12 266	27,042	13 082	28,840	9614	21,195	7061	15,567					100% Hydraulics Over End Over Side
	10 672	23,527	11 381	25,091	8364	18,440	6143	13,544					
	10 672	23,527	11 381	25,091	7676	16,923*	5302	11,688*					

*Stability limited capacities.

Standard Equipment

Standard equipment may vary. Consult your Cat dealer for details.

ELECTRICAL

- 24V system
- Master disconnect
- Circuit breaker protection
- 100 Amp alternator
- Two (2) 12V maintenance free batteries
- Standard lighting package
 - Two (2) cab mounted halogen light fixtures
- Auxiliary work light package
 - Two (2) rear cab mounted side facing lights, two (2) forward work lights, one (1) engine compartment service light

Electronic engine/machine monitoring system

- Two (2) 12V power points
- 20 circuit electric swivel
- Engine Auto Idle Down Feature
- 3 Operating Modes: Power, Run, Economy
- Cat Product Link™

OPERATOR ENVIRONMENT

- Cab with swing out front window guard
- Isolation mountings
- Dual joystick control (pilot hydraulic actuation) with foot pedal swing
- Electric stabilizer controls
- Integrated trailer landing gear control
- Pilot shut-off switch
- Push button throttle control
- Reverse slope windshield
- Skylight
- Tinted safety glass
- Sunshade – dual position for front window/skylight
- High back suspension seat with lumbar support
- High capacity AC/heater system with outside air intake
- Defroster fan
- Windshield wiper/washer
- Dome light
- Horn
- Radio-Includes: Digital AM/FM/Sirius Satellite Radio, Receiver with CD Player, USB Input, Auxiliary Input
- CB Radio ready – includes mounting bracket, power and ground wires, antenna cable and antenna mount bracket
- Cup holder
- Diagnostic port
- Cell phone storage tray

POWER TRAIN

- Cat C4.4 ACERT™ engine meets U.S. EPA Tier 4 Final emission standards
- 2-stage air cleaner
- Enlarged cooling package with isolated cores
- 378 L (100 U.S. gal) fuel tank
- 1:1 Fuel to DEF (Diesel Emission Fluid) Tank Refill Interval
- Fuel water separator
- Variable speed fan
- Ground level service fuel and engine oil filters

HYDRAULICS

- Twin 140 cm³ (8.54 in³) variable displacement pumps (105 cm³ for 559 rear pump)
- Excavator style “negacon” pump control system
- Bar slasher/delimiter hydraulic package
- 302 L (80 U.S. gal) hydraulic tank
- Hydraulic oil fill pump
- Single cylinder main boom

SAFETY

- Pilot accumulator for boom lowering
- Manual boom lowering control valve
- Secondary engine fuel shutoff switch
- Operator front protective safety cab guard meets SAE J2267
- Pilot enable alarm
- Stabilizer movement alarm

STRUCTURE AND SUBFRAME

- 653 kg (1,440 lb) counterweight (579D)
- Fabricated heavy-duty, extended length center mount sub-frame
- Flat top sub-frame deck with bolt-on skid resistant fenders
- Bolt-on sub-frame ladder

BOOMS AND STICKS

- 9.8 m (32 ft) reach knuckleboom
- 305 mm (12 in) grapple mounting knuckle

STRUCTURE AND SUBFRAME

- 653 kg (1,440 lb) counterweight (579D)
- Fabricated heavy-duty, extended length center mount sub-frame
- Flat top sub-frame deck with bolt-on skid resistant fenders
- Bolt-on sub-frame ladder

BOOMS AND STICKS

- 9.8 m (32 ft) reach knuckleboom
- Extended Single “V” or Double “V” bolt on heel
- 305 mm (12 in) grapple mounting knuckle

Optional Equipment

Optional equipment may vary. Consult your Cat dealer for details.

OTHER EQUIPMENT

SAFETY AND SECURITY

- Two additional subframe ladders

SAFETY AND SECURITY

- JIC to O-Ring Face Seal (ORFS) slasher adapter

DS SYSTEM

- Non-suspension trailer with hydraulic landing gear (559D)
- Crawler suspension trailer with hydraulic landing gear
- Delimber
 - DLK426 Delimber
- Grapple
 - GLK55 Grapple (SN, TW)
 - GLK48 Grapple (SN, TW)

For more complete information on Cat products, dealer services, and industry solutions, visit us on the web at www.cat.com

AEHQ6998-01 (09-2017)

© 2017 Caterpillar. All Rights Reserved.

Materials and specifications are subject to change without notice. Featured machines in photos may include additional equipment. See your Cat dealer for available options.

CAT, CATERPILLAR, BUILT FOR IT, their respective logos, "Caterpillar Yellow," the "Power Edge" trade dress as well as corporate and product identity used herein, are trademarks of Caterpillar and may not be used without permission. www.cat.com www.caterpillar.com

