

390F L

Hydraulic Excavator

2017



Engine

Engine Model	Cat® C18 ACERT™	
Power – ISO 14396	405 kW	543 hp
Power – ISO 9249	391 kW	524 hp

Drive

Maximum Travel Speed	4.5 km/h	2.8 mph
Maximum Drawbar Pull	590 kN	132,637 lbf

Weights

Minimum	70 970 kg	156,461 lb
Maximum	86 275 kg	190,204 lb

The 390F L is built to keep your production numbers up and your owning and operating costs down.

Not only does the machine's C18 ACERT engine meet U.S. EPA Tier 4 Final emission standards, but it does so while giving you all the power, fuel efficiency, and reliability you need to succeed.

Where the real power comes in is through advanced hydraulics and the new Adaptive Control System (ACS) valve. The ACS valve and other integrated components allow you to move tons of material all day long with a great deal of speed, precision, and efficiency. In fact, the hydraulic system and engine team worked together to lower fuel consumption up to 29% – with zero impact on your productivity – compared to 390D L.

When you add in a quiet operator environment that keeps you comfortable and productive, service points that make your routine maintenance quick and easy, and multiple Cat work tools that help you do a number of jobs very well, you simply won't find a better machine in this size class.



Contents

Reliable and Productive.....	4
Fuel Efficient.....	5
Easy to Operate.....	6
Durable Structures.....	8
Durable Linkages.....	9
Cat Connect Technologies.....	10
Versatile.....	12
Safe Work Environment.....	14
Serviceable.....	15
Sustainable.....	16
Complete Customer Care.....	16
Specifications.....	17
Standard Equipment.....	34
Optional Equipment.....	35





Reliable and Productive

Power to move your material with speed and precision

Hydraulic Horsepower, a Cat Advantage

Hydraulic horsepower is the actual machine power available to do work through implements and work tools. It's much more than just the engine power under the hood – it's a core strength that differentiates Cat machines from other brands. In fact, pump and other system components work to put more power to the ground, in a highly controlled, user-friendly way. This means you will move more material in less time and keep more money in your pocket at the end of the day.

Control Like No Other

The new Cat Adaptive Control System (ACS) valve optimizes performance by intelligently managing restrictions and flows to control machine motion, which means your operators will have the power and precision they need and expect. It opens slowly when your range of joystick lever movement is small and opens rapidly when movement is high. It smartly puts flow exactly where you need it when you need it, which leads to smoother operation, greater efficiency, and lower fuel consumption.

Auxiliary Hydraulics for Added Versatility

Auxiliary hydraulics give you greater tool versatility so you can take on more work with just one machine, and there are several options from which you can choose. A quick coupler circuit, for example, allows you to switch from one tool to another in a matter of minutes.

Fuel Efficient

Engineered to lower your operating costs

Proven Technology

The right technologies fine-tuned for the right applications result in:

- **Improved Fuel Efficiency** – Up to 29% improvement over Tier 4 Interim products.
- **High Performance** across a variety of applications.
- **Enhanced Reliability** through commonality and simplicity of design.
- **Maximized Uptime and Reduced Cost** with world-class support from the Cat dealer network.
- **Minimized Impact of Emission Systems** – designed to be transparent to the operator without requiring interaction.
- **Durable designs** with long life to overhaul.
- **Delivering better fuel economy** with minimized maintenance costs while providing the same great power and response.

The Cat C18 ACERT engine meets Tier 4 Final emission standards and it does so without interrupting your job process. Simply turn the engine on and go to work. It will look for opportunities in your work cycle to regenerate itself, and it will give you plenty of power for the task at hand – all to help keep your owning and operating costs to an absolute minimum.

A Smart Design for Any Temperature

The 390F L features a side-by-side cooling system that allows you to put the machine to work in extremely hot and cold conditions. The system is completely separated from the engine compartment to reduce noise and heat. Plus it features easy-to-clean cores and a new variable-speed fan that reverses to blow out unwanted debris that may accumulate during your work day.

Biodiesel Not A Problem

The C18 ACERT engine can run on biodiesel fuel up to B20 blended with ultra-low-sulfur diesel (ULSD). Just fill it up and go.



Easy to Operate

Comfort and convenience to keep you productive all day long



Safe and Quiet Cab

The cab contributes to your comfort thanks to special viscous mounts and special roof lining and sealing, that limit vibration and unnecessary sound.

Operators will enjoy the quietness and comfort of the all-new cab that's insulated to reduce sound inside by 4 dB over the previous model.

Excellent Ergonomics

Wide seats with air suspension and heat/cooling options, include a reclining back, upper and lower slide adjustments, and height and tilt angle adjustments to meet your needs for maximum comfort.

The fully automatic climate control system keeps operators comfortable and productive all day long in either hot or cold weather.

Storage spaces are located in the front, rear, and side consoles of the cab. A drink holder accommodates a large mug, and a shelf behind the seat stores large lunch or toolboxes.

Power supply sockets are available for charging your electronic devices like an MP3 player, a cell phone, or even a tablet.

Controls Just for You

The right and left joystick consoles can be adjusted to improve your comfort and productivity during the course of a day.

The right joystick features a button that will reduce engine speed when you are not working to help save fuel. Touch it once and speed reduces; touch it again and speed increases for normal operation.

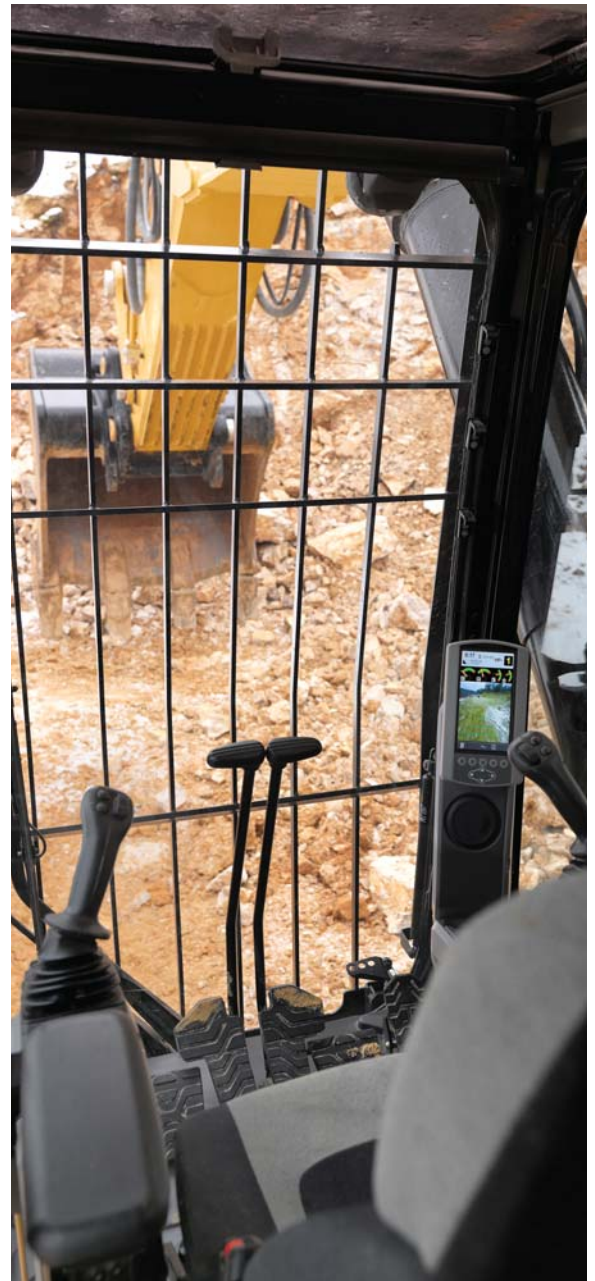

Easy to Navigate Monitor

The new LCD monitor is easy to see and navigate. Not only can it memorize up to 10 different work tools, it's also programmable in up to 44 languages to meet today's diverse workforce. The monitor clearly displays critical information you need to operate efficiently and effectively. Plus it projects the image from the standard rearview camera to help you see what's going on around you so you can stay safely focused on the job at hand.

Durable Structures

Made to work in your tough, heavy-duty applications



Stable Undercarriage

Long variable gauge undercarriage contributes significantly to its outstanding stability and durability, and it adjusts to reduce shipping width.

Track shoes, links, rollers, idlers, and final drives are all built with high-tensile strength steel for long-term durability.

Cat GLT4 track link protects moving parts by keeping water, debris, and dust out and grease sealed in, which delivers longer wear life and reduced noise when traveling.

Cat Positive Pin Retention 2 (PPR2) prevents looseness of the track pin in the track link, reduces stress concentrations, and eliminates pin walking for increased service life.



Robust Frames

The 390F L is a robust, well-built machine designed to give you a very long service life. The upper frame has mountings made specifically to support the heavy-duty cab. It's also reinforced around areas that take on a lot of stress like the boom foot, skirt, and counterweight.

Great Weight

An 11 mt (24,250 lb) counterweight – with or without removal device – is available to balance your work needs. Built with thick steel plates and reinforced fabrications to make it less susceptible to damage, the weight has a curved surface that matches the machine's sleek, smooth appearance along with an integrated housing to help protect the standard rearview camera.



Durable Linkages

Options to take on your far-reaching or up-close tasks

Booms and Sticks for Any Job

The 390F L is offered with a range of booms and sticks. Each is built with internal baffle plates and is stress relieved for added durability, and each undergoes ultrasound inspection to ensure quality and reliability. Large box-section structures with thick, multi-plate fabrications, castings, and forgings are used in high-stress areas such as the boom nose, boom foot, boom cylinder, and stick foot to improve durability. Also, the boom nose pin retention method is a captured flag design for enhanced durability.

The Reach boom and sticks offer you excellent all-around versatility for general excavation work like multipurpose digging and loading.

The Mass boom and sticks offer you enhanced performance in heavy-duty material like rock. They provide higher digging forces due to special boom and stick geometry, and bucket linkage and cylinders are built for greater durability.

Pins

All front linkage pins have thick chrome plating, giving them high wear resistance. Each pin diameter is made to distribute the shear and bending loads associated with the stick and to help ensure long pin, boom and stick life.

Talk to your Cat dealer to pick the best front linkage for your applications.

Cat Connect Technologies

Monitor, manage, and enhance job site operations



Cat Connect makes smart use of technology and services to improve your job site efficiency. Using the data from technology-equipped machines, you'll get more information and insight into your equipment and operations than ever before.

Cat Connect technologies offer improvements in these key areas:



EQUIPMENT
MANAGEMENT

Equipment Management – increase uptime and reduce operating costs.



PRODUCTIVITY

Productivity – monitor production and manage job site efficiency.



SAFETY

Safety – enhance job site awareness to keep your people and equipment safe.

PAYLOAD Technologies

Payload technologies accurately measure material being loaded or hauled. Payload data is shared with operators in real-time to improve productivity, reduce overloading, and record progress.

Cat Production Measurement

Cat Production Measurement brings payload weighing to the cab, enabling operators to weigh loads “on the go.” Loads are weighed as the boom swings with no interruptions in the loading cycle, improving loading speed and efficiency. Operators can view load weights on the integrated display and know precisely how much material is in the bucket and when trucks are filled to target payload. Instant feedback gives operators the confidence to work more effectively, maximizing the potential of the entire fleet. Site managers can wirelessly access data via the VisionLink® web portal to measure production and monitor efficiency.



GRADE Technologies

Grade technologies combine digital design data and in-cab guidance to help you reach target grade quickly and accurately, with minimal staking and checking. That means you'll be more productive, complete jobs faster, in fewer passes, using less fuel, at a lower cost.



Cat Grade Control Depth and Slope

The integrated Cat Grade Control system delivers 2D bucket tip elevation guidance to the cab to help operators create precise planes and slopes. Real-time bucket tip elevation guidance on the standard cab monitor indicates how much to cut or fill. Fast response sensors deliver immediate feedback, while optional integrated joystick buttons help operators make quick adjustments to maintain grade. Built-in alerts can be set to warn the operator if the linkage or bucket approaches a predefined elevation or depth, such as when working in areas with low ceilings, or digging near water lines. Staking and checking is minimized, which reduces ground crews and enhances job site safety.

Works best in simple 2D applications, such as digging trenches and basements or grading steep embankments.

Cat AccuGrade™

The AccuGrade system uses a dedicated monitor with a digital design plan for 3D bucket tip positioning and elevation guidance. AccuGrade indicates precisely where to work and how much to cut or fill – eliminating staking and checking.

Plug and play capability on the machine simplifies upgrading. Choose from satellite (GNSS) or total station (UTS) control for large projects with complex designs.

LINK Technologies

LINK technologies, like Product Link™, are deeply integrated into your machine and wirelessly communicates key information, including location, hours, fuel usage, idle time and event codes.

Product Link/VisionLink

Easy access to Product Link data via the online VisionLink user interface can help you see how your machine or fleet is performing. You can use this information to make timely, fact based decisions that can boost job site efficiency and productivity, and lower costs.



Versatile

Do more jobs with one machine





Get the Most from One Machine

The Cat combination of machine and tool provides a total solution for just about any application. Work tools can be mounted either directly to the machine or to a quick coupler, making it fast and easy to release one work tool and pick up another.

Change Jobs Quickly

Cat quick coupler brings the ability to quickly change attachments and switch from job to job. The Cat coupler is the secure way to decrease downtime and increase job site flexibility and overall productivity.

Available tool control remembers pressures and flows for up to 10 tools. Simply toggle through the monitor, select the tool, and go to work for maximum efficiency.

Dig, Rip and Load

A wide range of buckets dig everything from basic top soil to extreme, harsh material like ore and high quartzite granite. Rip through rock as an alternative to blasting in quarries. High-capacity buckets load trucks in a minimum number of passes for maximum productivity.

Break, Demolish and Scrap

A hydraulic hammer ably equips your machine for breaking rock in quarries. It will also make taking down bridge pillars and heavily reinforced concrete on road demolition jobs no problem.

Multi-processor and pulverizer attachments make your machine ideal for demolition jobs and processing the resulting debris.

Shears with 360° rotation mount to the machine for processing scrap steel and metal.

Move and Handle Material

When your job requires steady material handling and loading of heavy construction debris, a contractor's grapple is a good solution.

Set Up Your Machine for Profitability

Your Cat dealer can install hydraulic kits to properly operate all Cat Work Tool attachments, maximizing the machine's uptime and your profit. All Cat Work Tool attachments are supported by the same Cat dealer network as your Cat machine.

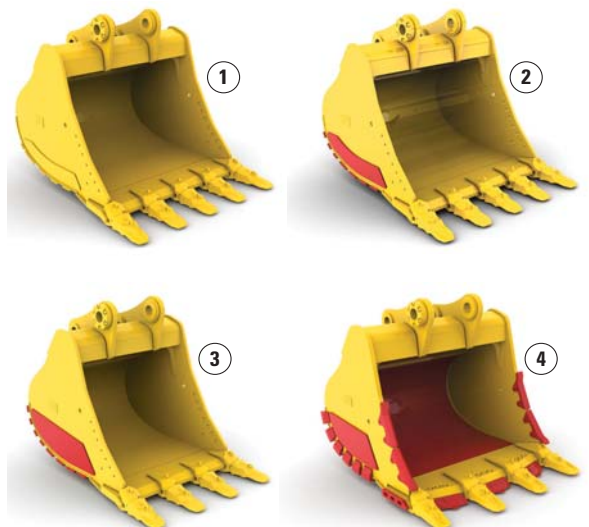

1) General Duty (GD) 2) Heavy Duty (HD)
3) Severe Duty (SD) 4) Extreme Duty (XD)

Safe Work Environment

Features to help protect you day in and day out



Great Views

Ample glass gives you excellent visibility out front and to the side, and the standard rearview camera gives you a clear field of view behind the machine through the cab monitor. As an option, a second display can be added, providing a dedicated full-time rearview of the job site. Optional side-view camera can also be added.

Halogen lights provide plenty of illumination. Cab and boom lights can be programmed to stay on for up to 90 seconds after the engine has been turned off to help you safely exit the machine. Optional High Intensity Discharge (HID) lights are available for enhanced night-time visibility.

Secure Contact Points

Multiple large steps as well as hand and guard rails will get you into the cab as well as a leg up to the catwalks and compartments. Extended hand and guard rails allow you to safely climb to the upper deck. Anti-skid plates on the catwalks, the surface of the upper structure, and the top of the storage box area reduce your slipping hazards in all types of weather conditions. They can be removed for cleaning.

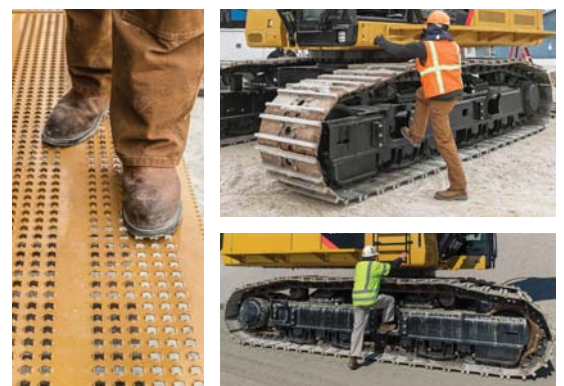

Serviceable

Designed to make your maintenance quick and easy

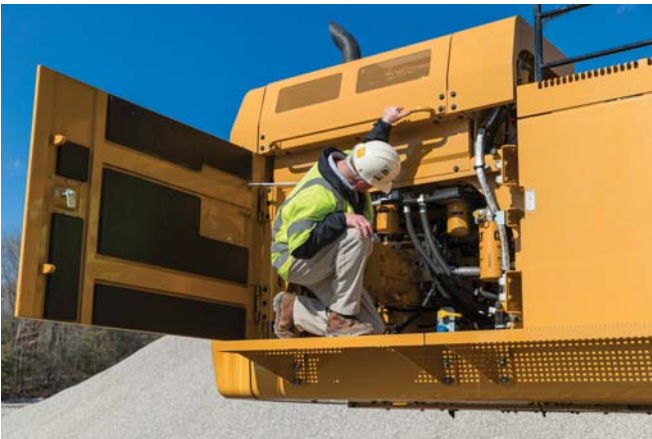

Convenient Access Built In

You can reach routine maintenance items like greasing points and a concentrated remote greasing block on boom foot from ground level.

Compartments feature wide service doors designed to help prevent debris entry, and they also securely latch in place to help make your service work simpler.

Machine's slip-resistant 500 mm (19.7 in) wide catwalks stretch the length of the machine to provide safe access to major and grouped service points, such as fuel and oil filters, and fluid taps.



Quick and Convenient Fluids Service

S-O-SSM Oil sample and pressure ports provide easy checking of machine condition and are standard on every machine.

You can ensure fast, easy, and secure changing of engine and hydraulic oil with the QuickEvacTM option.

The fuel tank's drain cock makes it easy and simple for you to remove water and sediment during routine maintenance. Plus an integrated fuel level indicator pops up to help you reduce the possibility of fuel tank overfilling. An optional fast fill port accessible from ground level can make refueling even easier and faster.

An electric lubricator system is an available time-saving attachment. The lubricator has a grease container, greasing pump, and a hose with nozzle to help you reach all the greasing points.

A Smart Cooling Design

The 390F L features a new side-by-side cooling system with easy-to-clean cores and a new variable-speed fan that reverses to blow out unwanted debris that may accumulate during your work day.

A Fresh Idea

Selecting ventilation inside the cab allows outside air to enter through a fresh air filter. The filter is conveniently located on the side of the cab to make it easy to reach and replace, and it is protected by a lockable door that can be opened with the engine key.





Complete Customer Care

Unmatched support makes the difference

Sustainable Generations ahead in every way

The 390F L is designed to compliment your business plan and minimize the consumption of natural resources, resulting in fewer emissions.

- The C18 ACERT engine meets Tier 4 Final emission standards.
- The 390F L consumes up to 30% less fuel than its predecessor 390D L.
- The machine has the flexibility to run on either ULSD fuel with 15 ppm of sulfur or less, or up to B20 biodiesel blended with ULSD.
- An overfill indicator rises when the tank is full to help the operator avoid spilling.
- Quick fill ports with connectors ensure fast, easy, and secure changing of hydraulic oil.
- Major components are rebuildable, eliminating waste and saving money by giving the machine and/or major components a second life – and even a third life.
- Link technologies enable you to collect and analyze equipment and job site data so you can maximize productivity and reduce costs.
- The 390F L is an efficient, productive machine that's designed to conserve our natural resources for generations ahead.

Worldwide Parts Availability

Cat dealers utilize a worldwide parts network to maximize your machines' uptime. Plus they can help you save money with Cat remanufactured components.

Financial Options Just for You

Consider financing options and day-to-day operating costs. Look at dealer services that can be included in the machine's cost to yield lower owning and operating costs over time.

What's Best for You Today...and Tomorrow

Repair, rebuild, or replace? Your Cat dealer can help you evaluate the cost involved so you can make the best choice for your business.



390F L Hydraulic Excavator Specifications

Engine

Engine Model	Cat C18 ACERT	
Engine Power – ISO 14396	405 kW	534 hp
Net Power – SAE J1349	391 kW	524 hp
Bore	145 mm	5.7 in
Stroke	183 mm	7.2 in
Displacement	18.1 L	1,104.5 in ³

- No engine power derating required below 2300 m (7,500 ft) altitude.
- Rating at 1,700 rpm (Implement).

Track

Track Options – Double Grouser:	900 mm	35 in
	750 mm	30 in
	650 mm	26 in
Number of Shoes Each Side	51	
Number of Track Rollers Each Side	9	
Number of Carrier Rollers Each Side	3	

Swing

Swing Speed	6.2 rpm	
Swing Torque	260 kN·m	191,766 lbf·ft
Maximum Swing Torque	313 kN·m	230,856 lbf·ft

Drive

Gradeability	30°/70%	
Maximum Travel Speed	4.5 km/h	2.8 mph
Maximum Drawbar Pull	590 kN	132,637 lbf

Service Refill Capacities

Fuel Tank Capacity	1240 L	328 gal
Cooling System	74 L	20 gal
Engine Oil	60 L	16 gal
Swing Drive (each)	19 L	5.0 gal
Final Drive (each)	21 L	5.5 gal
Hydraulic System (including tank)	997 L	263 gal
Hydraulic Tank	813 L	215 gal
DEF Tank	48 L	13 gal

Hydraulic System

Maximum Flow (total)		
Main System – Implement	952 L/min	251 gal/min
Main System – Travel	1064 L/min	281 gal/min
Pilot System	67 L/min	17.7 gal/min
Swing System	No swing pump	
Maximum Flow (× 2 pumps)		
Main System – Implement	476 L/min	133 gal/min
Main System – Travel	532 L/min	141 gal/min
Maximum Pressure		
Equipment – Normal	35 000 kPa	5,076 psi
Travel	35 000 kPa	5,076 psi
Swing	26 000 kPa	3,770 psi
Pilot System	4.0-4.4 MPa	580-638 psi
Boom Cylinder		
Bore	210 mm	8.3 in
Stroke	1967 mm	77 in
Stick Cylinder		
Bore	220 mm	8.7 in
Stroke	2262 mm	89 in
HB2 – Family Bucket Cylinder		
Bore	200 mm	7.9 in
Stroke	1451 mm	57 in
JC – Family Bucket Cylinder		
Bore	220 mm	8.7 in
Stroke	1586 mm	62 in

Sound Performance

Exterior – ISO 6395*	109 dB(A)
Interior – SAE J1166/ISO 6396	74 dB(A)

- Hearing protection may be needed when operating with an open operator station and cab (when not properly maintained or doors/windows open) for extended periods or in a noisy environment.
- When properly installed and maintained, the cab offered by Caterpillar, when tested with doors and windows closed according to ANSI/SAE J1166 OCT98, meets OSHA and MSHA requirements for operator sound exposure limits in effect at time of manufacture.

*as per European Union Directive 2000/14/EC as amended by 2005/88/EC

Standards

Brakes	ISO 10265:2008
Cab/FOGS	SAE J1356 MAR2013 ISO 10262:1998
DEF	ISO 22241

390F L Hydraulic Excavator Specifications

Dimensions

All dimensions are approximate. Dimensions may vary depending on bucket selection.

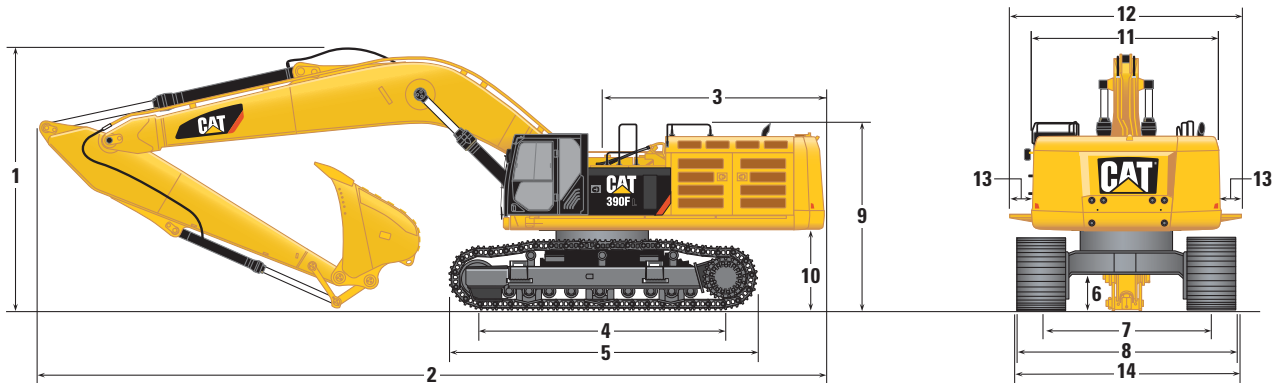

Boom Options		Reach Boom 10.0 m (32'10")		Mass Boom 7.25 m (23'9")		
Stick Options		R5.5HB2 (18'1")	R4.4HB2 (14'5")	M3.4JC (11'2")	M2.92JC (9'7")	
1	Height (with boom/stick installed)	mm (ft/in)	5490 (18'0")	5070 (16'8")	5310 (17'5")	4890 (16'1")
2	Length (with boom/stick installed)	mm (ft/in)	16 290 (53'5")	16 330 (53'7")	13 550 (44'6")	13 690 (44'11")
3	Tail Swing Radius	mm (ft/in)	4700 (15'5")	4700 (15'5")	4700 (15'5")	4700 (15'5")
4	Length to Center of Rollers	mm (ft/in)	5120 (16'10")	5120 (16'10")	5120 (16'10")	5120 (16'10")
5	Track Length	mm (ft/in)	6358 (20'10")	6358 (20'10")	6358 (20'10")	6358 (20'10")
6	Ground Clearance	mm (ft/in)	900 (2'11")	900 (2'11")	900 (2'11")	900 (2'11")
7	Track Gauge (retracted)	mm (ft/in)	2750 (9'0")	2750 (9'0")	2750 (9'0")	2750 (9'0")
	Track Gauge (extended)	mm (ft/in)	3510 (11'6")	3510 (11'6")	3510 (11'6")	3510 (11'6")
8	Transport Width					
	650 mm (26 in) Shoes	mm (ft/in)	4160 (13'8")	4160 (13'8")	4160 (13'8")	4160 (13'8")
	750 mm (30 in) Shoes	mm (ft/in)	4260 (14'0")	4260 (14'0")	4260 (14'0")	4260 (14'0")
	900 mm (35 in) Shoes	mm (ft/in)	4410 (14'6")	4410 (14'6")	4410 (14'6")	4410 (14'6")
9	Guardrail Height	mm (ft/in)	3830 (12'7")	3830 (12'7")	3830 (12'7")	3830 (12'7")
	Cab Height	mm (ft/in)	3650 (12'0")	3650 (12'0")	3650 (12'0")	3650 (12'0")
10	Counterweight Clearance	mm (ft/in)	1640 (5'5")	1640 (5'5")	1640 (5'5")	1640 (5'5")
11	Upperframe Width (without walkways)	mm (ft/in)	3470 (11'5")	3470 (11'5")	3470 (11'5")	3470 (11'5")
12	Upperframe Width (with walkways)	mm (ft/in)	4510 (14'10")	4510 (14'10")	4510 (14'10")	4510 (14'10")
13	Walkway Width (each)	mm (ft/in)	520 (1'9")	520 (1'9")	520 (1'9")	520 (1'9")
14	Undercarriage Width (without steps)					
	650 mm (26 in) Shoes	mm (ft/in)	4160 (13'8")	4160 (13'8")	4160 (13'8")	4160 (13'8")
	750 mm (30 in) Shoes	mm (ft/in)	4260 (14'0")	4260 (14'0")	4260 (14'0")	4260 (14'0")
	900 mm (35 in) Shoes	mm (ft/in)	4410 (14'6")	4410 (14'6")	4410 (14'6")	4410 (14'6")
	Undercarriage Width (including steps)					
	650 mm (26 in) Shoes	mm (ft/in)	4450 (14'7")	4450 (14'7")	4450 (14'7")	4450 (14'7")
	750 mm (30 in) Shoes	mm (ft/in)	4450 (14'7")	4450 (14'7")	4450 (14'7")	4450 (14'7")
	900 mm (35 in) Shoes	mm (ft/in)	4450 (14'7")	4450 (14'7")	4450 (14'7")	4450 (14'7")
	Bucket Type		GD	GD	SDV	SDV
	Bucket Capacity	m ³ (yd ³)	3.9 (5.1)	3.9 (5.1)	6.0 (7.84)	6.0 (7.84)
	Bucket Tip Radius	mm (ft/in)	2424 (7'11")	2424 (7'11")	2505 (8'3")	2505 (8'3")

390F L Hydraulic Excavator Specifications

Dimensions

All dimensions are approximate. Dimensions may vary depending on bucket selection.

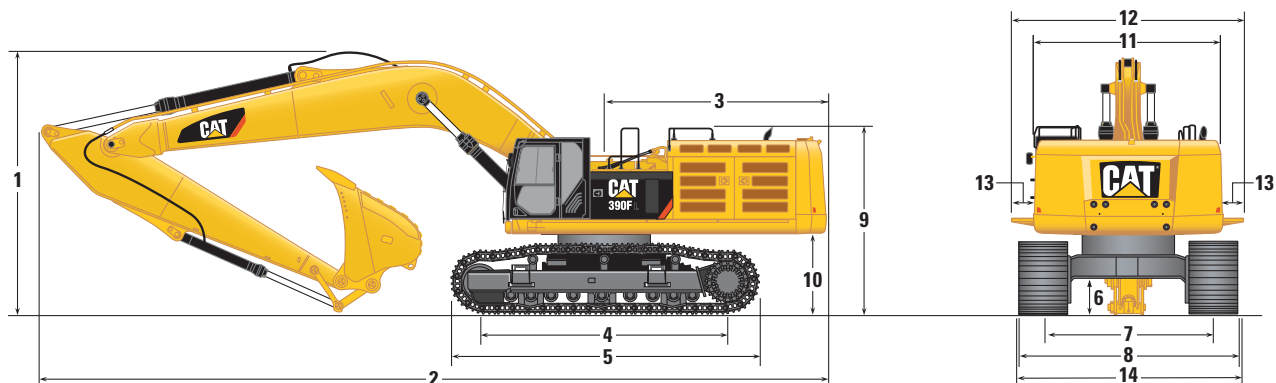

Boom Options

General Purpose Boom 8.4 m (27'7")

Stick Options		R5.5HB2 (18'1")	R4.4HB2 (14'5")	G3.4JC (11'2")	G2.92JC (9'7")
1 Height (with boom/stick installed)	mm (ft/in)	5840 (19'2")	5290 (17'4")	5160 (16'11")	5000 (16'5")
2 Length (with boom/stick installed)	mm (ft/in)	14 500 (47'7")	14 690 (48'2")	14 720 (48'4")	14 930 (49'0")
3 Tail Swing Radius	mm (ft/in)	4700 (15'5")	4700 (15'5")	4700 (15'5")	4700 (15'5")
4 Length to Center of Rollers	mm (ft/in)	5120 (16'10")	5120 (16'10")	5120 (16'10")	5120 (16'10")
5 Track Length	mm (ft/in)	6358 (20'10")	6358 (20'10")	6358 (20'10")	6358 (20'10")
6 Ground Clearance	mm (ft/in)	900 (2'11")	900 (2'11")	900 (2'11")	900 (2'11")
7 Track Gauge (retracted)	mm (ft/in)	2750 (9'0")	2750 (9'0")	2750 (9'0")	2750 (9'0")
Track Gauge (extended)	mm (ft/in)	3510 (11'6")	3510 (11'6")	3510 (11'6")	3510 (11'6")
8 Transport Width					
650 mm (26 in) Shoes	mm (ft/in)	4160 (13'8")	4160 (13'8")	4160 (13'8")	4160 (13'8")
750 mm (30 in) Shoes	mm (ft/in)	4260 (14'0")	4260 (14'0")	4260 (14'0")	4260 (14'0")
900 mm (35 in) Shoes	mm (ft/in)	4410 (14'6")	4410 (14'6")	4410 (14'6")	4410 (14'6")
9 Guardrail Height	mm (ft/in)	3830 (12'7")	3830 (12'7")	3830 (12'7")	3830 (12'7")
Cab Height	mm (ft/in)	3650 (12'0")	3650 (12'0")	3650 (12'0")	3650 (12'0")
10 Counterweight Clearance	mm (ft/in)	1640 (5'5")	1640 (5'5")	1640 (5'5")	1640 (5'5")
11 Upperframe Width (without walkways)	mm (ft/in)	3470 (11'5")	3470 (11'5")	3470 (11'5")	3470 (11'5")
12 Upperframe Width (with walkways)	mm (ft/in)	4510 (14'10")	4510 (14'10")	4510 (14'10")	4510 (14'10")
13 Walkway Width (each)	mm (ft/in)	520 (1'9")	520 (1'9")	520 (1'9")	520 (1'9")
14 Undercarriage Width (without steps)					
650 mm (26 in) Shoes	mm (ft/in)	4160 (13'8")	4160 (13'8")	4160 (13'8")	4160 (13'8")
750 mm (30 in) Shoes	mm (ft/in)	4260 (14'0")	4260 (14'0")	4260 (14'0")	4260 (14'0")
900 mm (35 in) Shoes	mm (ft/in)	4410 (14'6")	4410 (14'6")	4410 (14'6")	4410 (14'6")
Undercarriage Width (including steps)					
650 mm (26 in) Shoes	mm (ft/in)	4450 (14'7")	4450 (14'7")	4450 (14'7")	4450 (14'7")
750 mm (30 in) Shoes	mm (ft/in)	4450 (14'7")	4450 (14'7")	4450 (14'7")	4450 (14'7")
900 mm (35 in) Shoes	mm (ft/in)	4450 (14'7")	4450 (14'7")	4450 (14'7")	4450 (14'7")
Bucket Type		GD	GD	SD	SD
Bucket Capacity	m ³ (yd ³)	4.6 (6.0)	4.6 (6.0)	4.6 (6.0)	4.6 (6.0)
Bucket Tip Radius	mm (ft/in)	2319 (7'7")	2319 (7'7")	2319 (7'7")	2319 (7'7")

390F L Hydraulic Excavator Specifications

Working Ranges

All dimensions are approximate. Dimensions may vary depending on bucket selection.

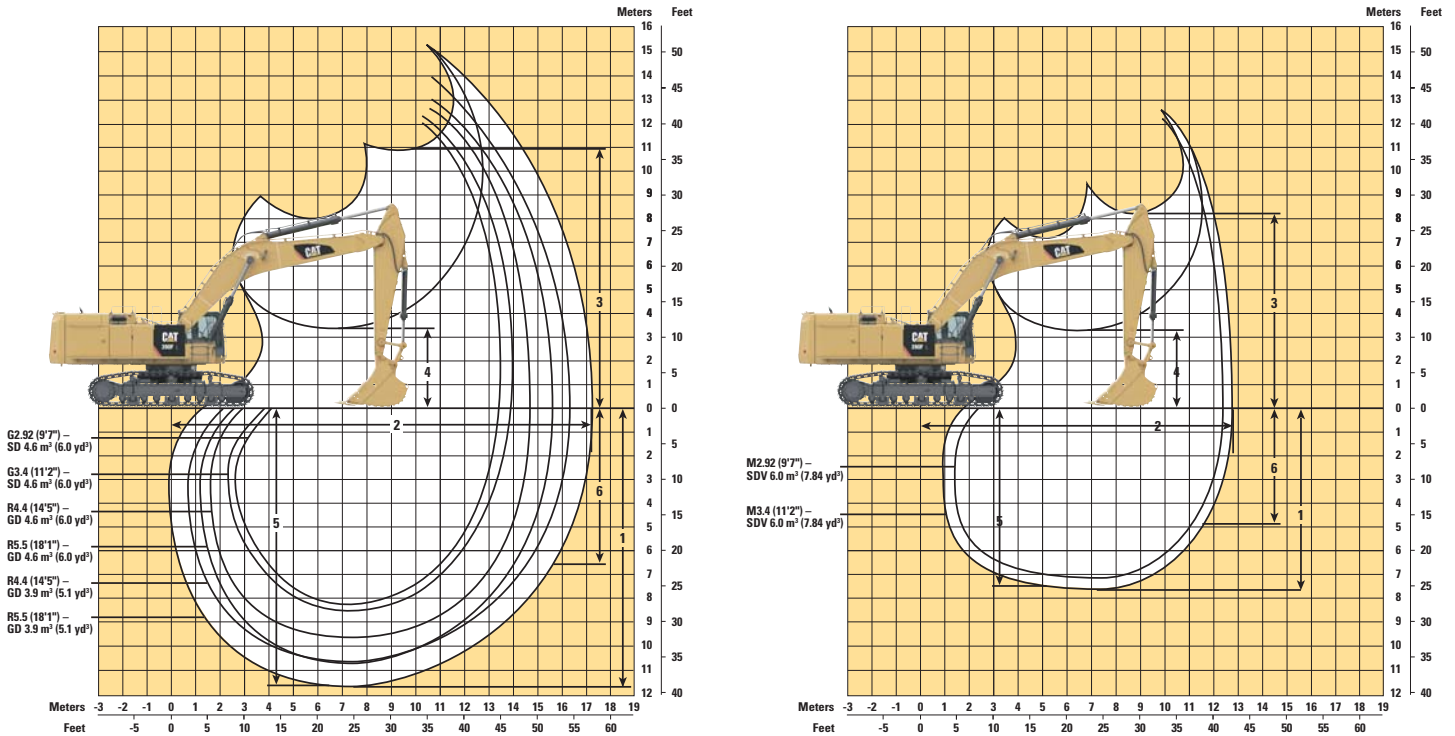

Boom Options

Reach Boom
10.0 m (32'10")

General Purpose Boom
8.4 m (27'7")

Mass Boom
7.25 m (23'9")

Stick Options

R5.5 m
(18'1")

R4.4 m
(14'5")

R5.5 m
(18'1")

R4.4 m
(14'5")

G3.4 m
(11'2")

G2.92 m
(9'7")

M3.4 m
(11'2")

M2.92 m
(9'7")

Bucket

GD 3.9 m³
(5.1 yd³)

GD 3.9 m³
(5.1 yd³)

GD 4.6 m³
(6.0 yd³)

GD 4.6 m³
(6.0 yd³)

SD 4.6 m³
(6.0 yd³)

SD 4.6 m³
(6.0 yd³)

SDV 6.0 m³
(7.84 yd³)

SDV 6.0 m³
(7.84 yd³)

		R5.5 m (18'1")	R4.4 m (14'5")	R5.5 m (18'1")	R4.4 m (14'5")	G3.4 m (11'2")	G2.92 m (9'7")	M3.4 m (11'2")	M2.92 m (9'7")
1 Maximum Digging Depth	mm	11 800	10 700	10 750	9650	8680	8210	7640	7160
	ft/in	38'9"	35'1"	35'3"	31'8"	28'6"	26'11"	25'1"	23'6"
2 Maximum Reach at Ground Line	mm	17 250	16 230	15 730	14 690	13 910	13 450	12 680	12 230
	ft/in	56'7"	53'3"	51'7"	48'2"	45'8"	44'1"	41'7"	40'1"
3 Maximum Loading Height	mm	10 960	10 530	9730	9280	9100	8860	8210	7990
	ft/in	36'0"	34'7"	31'11"	30'5"	29'10"	29'0"	26'11"	26'3"
4 Minimum Loading Height	mm	3320	4420	1950	3050	4030	4500	3210	3680
	ft/in	10'11"	14'6"	6'5"	10'0"	13'3"	14'9"	10'6"	12'1"
5 Maximum Depth Cut for 2240 mm (8'0") Level Bottom	mm	11 700	10 590	10 650	9540	8550	8070	7510	7020
	ft/in	38'5"	34'9"	34'11"	31'4"	28'1"	26'6"	24'8"	23'0"
6 Maximum Vertical Wall Digging Depth	mm	6670	5730	6330	5390	5960	5570	4920	4530
	ft/in	21'10"	18'9"	20'9"	17'8"	19'6"	18'3"	16'1"	14'10"
Maximum Cutting Height	mm	15 180	14 750	14 000	13 540	13 470	13 240	12 580	12 360
	ft/in	49'10"	48'5"	45'11"	44'5"	44'2"	43'5"	41'3"	40'7"
Bucket Digging Force (SAE)	kN	322	321	322	321	412	411	404	404
	lbf	72,400	72,100	72,400	72,100	92,600	92,400	90,900	90,800
Bucket Digging Force (ISO)	kN	365	363	365	363	471	470	471	470
	lbf	82,000	81,700	82,000	81,700	105,900	105,800	105,900	105,800
Stick Digging Force (SAE)	kN	230	268	230	268	315	343	314	342
	lbf	51,700	60,200	51,700	60,200	70,800	77,200	70,500	76,800
Stick Digging Force (ISO)	kN	236	276	236	276	326	356	326	356
	lbf	53,000	62,000	53,000	62,000	73,200	80,100	73,200	80,100

390F L Hydraulic Excavator Specifications

Operating Weights and Ground Pressures

	900 mm (35 in) Double Grouser Shoes				750 mm (30 in) Double Grouser Shoes				650 mm (26 in) Double Grouser Shoes			
	Weight		Ground Pressure		Weight		Ground Pressure		Weight		Ground Pressure	
	kg	lb	kPa	psi	kg	lb	kPa	psi	kg	lb	kPa	psi
Reach Boom – 10.0 m (32'10")												
3.9 m ³ (5.1 yd ³) GD Bucket												
R5.5 m (18'1") Stick	89 830	198,000	88.1	12.8	88 780	195,700	104.5	15.2	87 910	193,800	119.4	17.3
R4.4 m (14'5") Stick	89 320	196,900	87.6	12.7	88 275	194,600	103.9	15.1	87 400	192,700	118.7	17.2
General Purpose Boom – 8.4 m (27'7")												
4.6 m ³ (6.0 yd ³) GD Bucket												
R5.5 m (18'1") Stick	88 705	195,600	87.0	12.6	87 660	193,300	103.2	15.0	86 785	191,300	117.8	17.1
R4.4 m (14'5") Stick	88 200	194,400	86.5	12.5	87 150	192,100	102.6	14.9	86 275	190,200	117.2	17.0
4.6 m ³ (6.0 yd ³) SD Bucket												
G3.4 m (11'2") Stick	90 605	199,700	88.9	12.9	89 560	197,400	105.4	15.3	88 685	195,500	120.4	17.5
G2.92 m (9'7") Stick	90 300	199,100	88.6	12.9	89 255	196,800	105.0	15.2	88 380	194,800	120.0	17.4
Mass Boom – 7.25 m (23'9")												
6.0 m ³ (7.84 yd ³) SDV Bucket												
M3.4 m (11'2") Stick	92 025	202,900	90.3	13.1	90 975	200,600	107.1	15.5	90 105	198,600	122.4	17.8
M2.92 m (9'7") Stick	91 765	202,300	90.0	13.1	90 720	200,000	106.8	15.5	89 845	198,100	122.0	17.7

Major Component Weights

	kg	lb
Base Machine (with counterweight, without front linkage, without bucket)*		
650 mm (26 in) Shoes without Front Linkage	66 739	147,134
750 mm (30 in) Shoes without Front Linkage	67 613	149,061
900 mm (35 in) Shoes without Front Linkage	68 660	151,369
Two Boom Cylinders	1804	3,977
Counterweight Removal type	12 400	27,300
Counterweight Non Removal type	12 400	27,300
10.0 m (32'10") Reach Boom (includes lines, pins, stick cylinder)	9840	21,700
8.4 m (27'7") General Purpose Boom (includes lines, pins, stick cylinder)	8395	18,500
7.25 m (23'9") Mass Boom (includes lines, pins, stick cylinder)	8440	18,600
R5.5 m (18'1") Stick (includes lines, pins, bucket cylinder and linkage)	5430	12,000
R4.4 m (14'5") Stick (includes lines, pins, bucket cylinder and linkage)	4925	10,900
G3.4 m (11'2") Stick (includes lines, pins, bucket cylinder and linkage)	5190	11,400
G2.92 m (9'7") Stick (includes lines, pins, bucket cylinder and linkage)	4885	10,800
M3.4 m (11'2") Stick (includes lines, pins, bucket cylinder and linkage)	5450	12,000
M2.92 m (9'7") Stick (includes lines, pins, bucket cylinder and linkage)	5190	11,400
Bucket		
3.9 m ³ (5.1 yd ³) GD	4095	9,000
4.6 m ³ (6.0 yd ³) GD	4420	9,700
6.0 m ³ (7.84 yd ³) SDV	7675	16,900

*Base machine includes 75 kg (165 lb) operator weight and 90% fuel weight, and undercarriage with center guard.

390F L Hydraulic Excavator Specifications

Reach Boom Lift Capacities – Counterweight: 12.4 mt (27,337 lb) – without Bucket

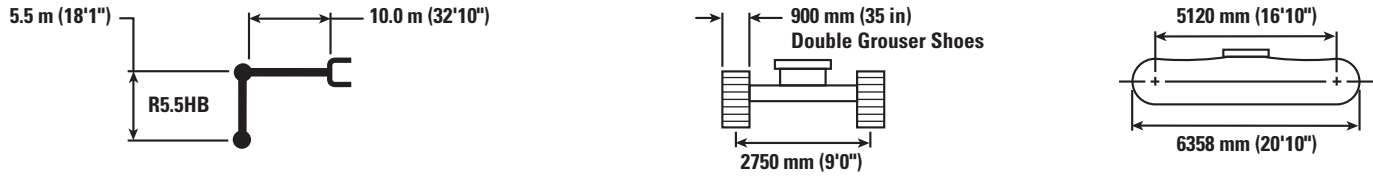

		3.0 m/10.0 ft		4.5 m/15.0 ft		6.0 m/20.0 ft		7.5 m/25.0 ft		9.0 m/30.0 ft				
														m ft
12.0 m 40.0 ft	kg lb											*9600 *21,300	*9600 *21,300	11.83 38.81
10.5 m 35.0 ft	kg lb											*9300 *20,500	*9300 *20,500	12.88 42.26
9.0 m 30.0 ft	kg lb											*9150 *20,150	*9150 *20,150	13.68 44.88
7.5 m 25.0 ft	kg lb											*9150 *20,100	8350 18,550	14.28 46.85
6.0 m 20.0 ft	kg lb							*19 800 *42,650	*19 800 *42,650	*16 850 *36,400	*16 850 *36,400	*9250 *20,350	7700 17,050	14.69 48.20
4.5 m 15.0 ft	kg lb					*28 600 *61,450	*28 600 *61,450	*22 050 *47,550	*22 050 *47,550	*18 250 *39,450	17 150 36,950	*9500 *20,900	7300 16,050	14.95 49.05
3.0 m 10.0 ft	kg lb					*20 000 *49,350	*20 000 *49,350	*24 050 *51,900	20 750 44,850	*19 550 *42,250	16 050 34,600	*9900 *21,750	7000 15,450	15.05 49.38
1.5 m 5.0 ft	kg lb					*15 650 *37,200	*15 650 *37,200	*25 400 *54,900	19 450 42,000	*20 550 *44,400	15 150 32,650	*10 450 *23,000	6900 15,150	14.99 49.18
0 m 0 ft	kg lb					*16 950 *39,400	*16 950 *39,400	*25 950 *56,200	18 600 40,150	*21 100 *45,650	14 450 31,150	10 950 24,100	6900 15,200	14.79 48.52
-1.5 m -5.0 ft	kg lb			*11 250 *25,700	*11 250 *25,700	*20 650 *47,600	*20 650 *47,600	*25 800 *55,850	18 150 39,100	*21 150 *45,750	14 050 30,250	11 250 24,850	7100 15,650	14.42 47.31
-3.0 m -10.0 ft	kg lb	*12 200 *27,500	*12 200 *27,500	*16 750 *37,950	*16 750 *37,950	*26 100 *59,850	25 350 54,500	*24 950 *54,000	18 000 38,750	*20 650 *44,650	13 850 29,800	11 900 *26,200	7500 16,550	13.88 45.54
-4.5 m -15.0 ft	kg lb	*17 800 *40,100	*17 800 *40,100	*22 900 *51,950	*22 900 *51,950	*28 300 *61,300	25 600 55,050	*23 400 *50,600	18 100 38,900	*19 550 *42,200	13 850 29,800	*11 800 *26,000	8200 18,100	13.14 43.11
-6.0 m -20.0 ft	kg lb	*24 050 *54,250	*24 050 *54,250	*30 050 *64,950	*30 050 *64,950	*25 150 *54,250	*25 150 *54,250	*21 100 *45,400	18 350 39,550	*17 700 *38,000	14 000 30,200	*11 500 *25,300	9300 20,650	12.17 39.93
-7.5 m -25.0 ft	kg lb			*24 250 *51,950	*24 250 *51,950	*20 850 *44,600	*20 850 *44,600	*17 700 *37,750	*17 700 *37,750	*14 800 *31,300	14 450 31,200	*10 850 *23,700	*10 850 *23,700	10.91 35.79
-9.0 m -30.0 ft	kg lb					*14 850 *32,600	*14 850 *32,600	*12 650 *26,000	*12 650 *26,000	*9800 *21,850	*9800 *21,850	*9250 *19,850	*9250 *19,850	9.23 30.28



ISO 10567



*Indicates that the load is limited by hydraulic lifting capacity rather than tipping load. The above loads are in compliance with hydraulic excavator lift capacity standard ISO 10567:2007. They do not exceed 87% of hydraulic lifting capacity or 75% of tipping load. Weight of all lifting accessories must be deducted from the above lifting capacities. Lifting capacities are based on the machine standing on a firm, uniform supporting surface. The use of a work tool attachment point to handle/lift objects, could affect the machine lift performance.

Lift capacity stays with $\pm 5\%$ for all available track shoes.









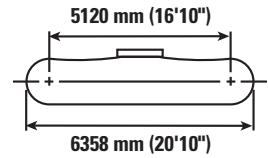
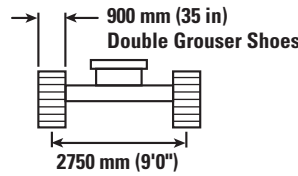

Always refer to the appropriate Operation and Maintenance Manual for specific product information.

(continued on next page)

390F L Hydraulic Excavator Specifications

Reach Boom Lift Capacities – Counterweight: 12.4 mt (27,337 lb) – without Bucket (continued)



		10.5 m/35.0 ft		12.0 m/40.0 ft		13.5 m/45.0 ft		15.0 m/50.0 ft				
												m ft
12.0 m 40.0 ft	kg lb									*9600 *21,300	*9600 *21,300	11.83 38.81
10.5 m 35.0 ft	kg lb			*12 100 *25,100	*12 100 *25,100					*9300 *20,500	*9300 *20,500	12.88 42.26
9.0 m 30.0 ft	kg lb	*13 350 *29,050	*13 350 *29,050	*12 550 *27,350	12 100 25,900	*10 050 9550				*9150 *20,150	*9150 *20,150	13.68 44.88
7.5 m 25.0 ft	kg lb	*14 000 *30,400	*14 000 *30,400	*12 900 *28,100	11 800 25,250	*12 100 *25,450	9400 20,050			*9150 *20,100	8350 18,550	14.28 46.85
6.0 m 20.0 ft	kg lb	*14 850 *32,150	14 250 30,650	*13 400 *29,150	11 350 24,350	*12 350 *26,900	9150 19,600			*9250 *20,350	7700 17,050	14.69 48.20
4.5 m 15.0 ft	kg lb	*15 750 *34,100	13 500 29,050	*14 000 *30,350	10 850 23,350	*12 700 *27,600	8850 18,950			*9500 *20,900	7300 16,050	14.95 49.05
3.0 m 10.0 ft	kg lb	*16 600 *35,950	12 800 27,500	*14 550 *31,550	10 400 22,300	*13 000 28,200	8550 18,300	*10 250 7050		*9900 *21,750	7000 15,450	15.05 49.38
1.5 m 5.0 ft	kg lb	*17 300 *37,400	12 150 26,150	*15 000 *32,450	9950 21,350	12 800 27,550	8250 17,650			*10 450 *23,000	6900 15,150	14.99 49.18
0 m 0 ft	kg lb	*17 700 *38,300	11 650 25,050	15 000 32,200	9600 20,600	12 550 27,000	8000 17,150			10 950 24,100	6900 15,200	14.79 48.52
-1.5 m -5.0 ft	kg lb	*17 750 *38,400	11 300 24,300	14 700 31,650	9300 20,050	12 400 26,650	7850 16,850			11 250 24,850	7100 15,650	14.42 47.31
-3.0 m -10.0 ft	kg lb	*17 400 *37,550	11 100 23,950	14 550 31,350	9200 19,800	12 350 26,600	7800 16,800			11 900 *26,200	7500 16,550	13.88 45.54
-4.5 m -15.0 ft	kg lb	*16 450 *35,450	11 100 23,900	*13 850 *29,600	9200 19,850					*11 800 *26,000	8200 18,100	13.14 43.11
-6.0 m -20.0 ft	kg lb	*14 800 *31,550	11 250 24,300	*11 900 9450						*11 500 *25,300	9300 20,650	12.17 39.93
-7.5 m -25.0 ft	kg lb	*11 800 *24,350	11 700 *24,350							*10 850 *23,700	*10 850 *23,700	10.91 35.79
-9.0 m -30.0 ft	kg lb									*9250 *19,850	*9250 *19,850	9.23 30.28



ISO 10567



*Indicates that the load is limited by hydraulic lifting capacity rather than tipping load. The above loads are in compliance with hydraulic excavator lift capacity standard ISO 10567:2007. They do not exceed 87% of hydraulic lifting capacity or 75% of tipping load. Weight of all lifting accessories must be deducted from the above lifting capacities. Lifting capacities are based on the machine standing on a firm, uniform supporting surface. The use of a work tool attachment point to handle/lift objects, could affect the machine lift performance.

Lift capacity stays with ±5% for all available track shoes.

Always refer to the appropriate Operation and Maintenance Manual for specific product information.

390F L Hydraulic Excavator Specifications

Reach Boom Lift Capacities – Counterweight: 12.4 mt (27,337 lb) – without Bucket

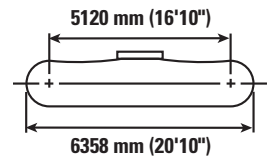
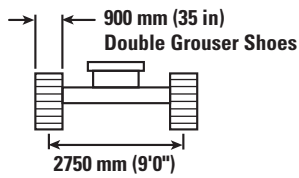
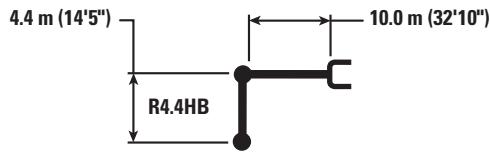

		4.5 m/15.0 ft		6.0 m/20.0 ft		7.5 m/25.0 ft		9.0 m/30.0 ft		10.5 m/35.0 ft		12.0 m/40.0 ft		13.5 m/45.0 ft		m ft		
12.0 m 40.0 ft	kg lb									*13 000	*13 000					*12 950	*12 950	10.51
10.5 m 35.0 ft	kg lb									*14 450	*14 450					*12 450	*12 450	11.68
9.0 m 30.0 ft	kg lb									*14 750	*14 750	*13 800	11 800			*12 250	10 750	12.56
7.5 m 25.0 ft	kg lb							*17 150	*17 150	*15 300	14 550	*14 050	11 550			*12 250	9600	13.21
6.0 m 20.0 ft	kg lb			*28 100	*28 100	*21 950	*21 950	*18 400	17 750	*16 100	13 950	*14 500	11 200	*13 350	9050	*12 450	8850	13.66
4.5 m 15.0 ft	kg lb					*24 050	21 600	*19 700	16 700	*16 900	13 300	*14 950	10 750	13 400	8800	12 700	8350	13.94
3.0 m 10.0 ft	kg lb					*25 700	20 150	*20 750	15 750	*17 600	12 650	*15 350	10 350	13 150	8600	12 350	8000	14.04
1.5 m 5.0 ft	kg lb					*26 450	19 200	*21 450	15 050	*18 050	12 150	15 400	10 000	12 900	8350	12 250	7900	13.98
0 m 0 ft	kg lb					*57,250	41,450	*46,450	32,400	*39,100	26,150	33,150	21,550	27,800	17,950	27,000	17,400	45.87
0 m 0 ft	kg lb			*13 250	*13 250	*26 400	18 700	*21 650	14 550	*18 250	11 750	15 100	9750	12 750	8200	12 400	8000	13.76
-1.5 m -5.0 ft	kg lb			*20 150	*20 150	*25 600	18 500	*21 300	14 300	*18 000	11 550	14 950	9600			12 900	8250	13.37
-3.0 m -10.0 ft	kg lb	*18 050	*18 050	*28 450	26 250	*24 200	18 550	*20 350	14 250	*17 200	11 500	*14 500	9550			*13 050	8850	12.78
-4.5 m -15.0 ft	kg lb	*26 900	*26 900	*25 800	*25 800	*22 100	18 750	*18 750	14 350	*15 750	11 600					*12 800	9800	11.97
-6.0 m -20.0 ft	kg lb	*24 450	*24 450	*22 000	*22 000	*19 100	*19 100	*16 150	14 700	*13 100	11 950					*12 150	11 400	10.90
-7.5 m -25.0 ft	kg lb			*16 750	*16 750	*14 650	*14 650	*11 850	*11 850							*10 750	*10 750	9.46

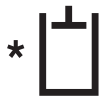

ISO 10567



*Indicates that the load is limited by hydraulic lifting capacity rather than tipping load. The above loads are in compliance with hydraulic excavator lift capacity standard ISO 10567:2007. They do not exceed 87% of hydraulic lifting capacity or 75% of tipping load. Weight of all lifting accessories must be deducted from the above lifting capacities. Lifting capacities are based on the machine standing on a firm, uniform supporting surface. The use of a work tool attachment point to handle/lift objects, could affect the machine lift performance.

Lift capacity stays with ±5% for all available track shoes.

Always refer to the appropriate Operation and Maintenance Manual for specific product information.

390F L Hydraulic Excavator Specifications

General Purpose Boom Lift Capacities – Counterweight: 12.4 mt (27,337 lb) – without Bucket

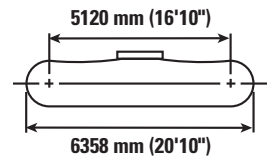
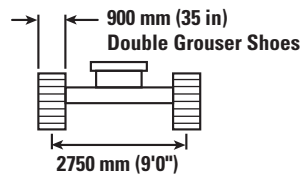
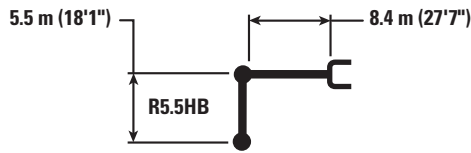

Reach		1.5 m/5.0 ft		3.0 m/10.0 ft		4.5 m/15.0 ft		6.0 m/20.0 ft		7.5 m/25.0 ft		m ft		
		kg lb	kg lb	kg lb	kg lb	kg lb	kg lb	kg lb	kg lb	kg lb	kg lb	kg lb	kg lb	
12.0 m 40.0 ft	kg lb											*8950 *19,900	*8950 *19,900	9.84 32.28
10.5 m 35.0 ft	kg lb											*8350 *18,500	*8350 *18,500	11.08 36.35
9.0 m 30.0 ft	kg lb											*8050 *17,750	*8050 *17,750	12.01 39.40
7.5 m 25.0 ft	kg lb											*7950 *17,450	*7950 *17,450	12.68 41.60
6.0 m 20.0 ft	kg lb											*7950 *17,500	*7950 *17,500	13.15 43.14
4.5 m 15.0 ft	kg lb							*26 650 *57,450	*26 650 *57,450	*21 800 *47,150	*21 800 *47,150	*8100 *17,850	*8100 *17,850	13.44 44.09
3.0 m 10.0 ft	kg lb							*31 000 *66,850	*31 000 *66,850	*24 350 *52,650	23 250 50,150	*8450 *18,550	*8450 *18,550	13.55 44.46
1.5 m 5.0 ft	kg lb							*34 200 *73,900	30 450 65,650	*26 450 *57,200	22 000 47,400	*8900 *19,600	*8900 *19,600	13.49 44.26
0 m 0 ft	kg lb					*18 900 *43,300	*18 900 *43,300	*35 800 *77,500	29 150 62,750	*27 750 *60,100	21 050 45,400	*9600 *21,100	9150 20,200	13.26 43.50
-1.5 m -5.0 ft	kg lb			*14 150 *31,800	*14 150 *31,800	*23 150 *52,650	*23 150 *52,650	*35 900 *77,750	28 500 61,250	*28 150 *60,950	20 500 44,100	*10 550 *23,300	9500 21,000	12.84 42.13
-3.0 m -10.0 ft	kg lb	*16 300 *36,350	*16 300 *36,350	*20 100 *45,200	*20 100 *45,200	*29 350 *66,650	*29 350 *66,650	*34 700 *75,100	28 250 60,750	*27 550 *59,600	20 200 43,500	*12 050 *26,600	10 200 22,500	12.23 40.12
-4.5 m -15.0 ft	kg lb	*22 150 *49,600	*22 150 *49,600	*27 000 *60,800	*27 000 *60,800	*37 700 *85,800	*37 700 *85,800	*32 150 *69,450	28 350 61,000	*25 850 *55,750	20 200 43,550	*14 300 *31,850	11 350 25,150	11.39 37.37
-6.0 m -20.0 ft	kg lb			*35 500 *80,350	*35 500 *80,350	*35 100 *75,500	*35 100 *75,500	*28 000 *60,150	*28 000 *60,150	*22 650 *48,500	20 500 44,200	*14 450 *31,700	13 350 29,800	10.25 33.63
-7.5 m -25.0 ft	kg lb					*26 500 *55,950	*26 500 *55,950	*21 600 *45,450	*21 600 *45,450	*17 150 *35,600	*17 150 *35,600	*13 200 *28,700	*13 200 *28,700	8.71 28.58



ISO 10567



*Indicates that the load is limited by hydraulic lifting capacity rather than tipping load. The above loads are in compliance with hydraulic excavator lift capacity standard ISO 10567:2007. They do not exceed 87% of hydraulic lifting capacity or 75% of tipping load. Weight of all lifting accessories must be deducted from the above lifting capacities. Lifting capacities are based on the machine standing on a firm, uniform supporting surface. The use of a work tool attachment point to handle/lift objects, could affect the machine lift performance.

Lift capacity stays with ±5% for all available track shoes.









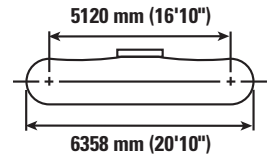
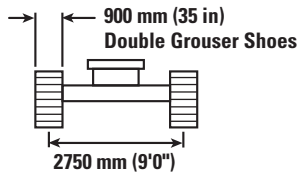
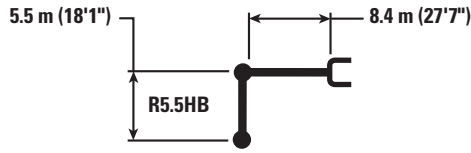

Always refer to the appropriate Operation and Maintenance Manual for specific product information.

(continued on next page)

390F L Hydraulic Excavator Specifications

General Purpose Boom Lift Capacities – Counterweight: 12.4 mt (27,337 lb) – without Bucket (continued)



		9.0 m/30.0 ft		10.5 m/35.0 ft		12.0 m/40.0 ft		13.5 m/45.0 ft				
												m ft
12.0 m 40.0 ft	kg lb									*8950 *19,900	*8950 *19,900	9.84 32.28
10.5 m 35.0 ft	kg lb			*10 850 *21,700	*10 850 *21,700					*8350 *18,500	*8350 *18,500	11.08 36.35
9.0 m 30.0 ft	kg lb			*12 900 *27,500	*12 900 *27,500	*8050	*8050			*8050 *17,750	*8050 *17,750	12.01 39.40
7.5 m 25.0 ft	kg lb			*14 300 *30,850	*14 300 *30,850	*11 400 *22,950	*11 400 *22,950			*7950 *17,450	*7950 *17,450	12.68 41.60
6.0 m 20.0 ft	kg lb	*17 300 *37,500	*17 300 *37,500	*15 850 *34,550	15 050 32,350	*13 400 *27,950	11 950 25,600			*7950 *17,500	*7950 *17,500	13.15 43.14
4.5 m 15.0 ft	kg lb	*18 800 *40,800	18 550 40,000	*16 800 *36,550	14 500 31,200	*15 250 *32,100	11 600 24,950			*8100 *17,850	*8100 *17,850	13.44 44.09
3.0 m 10.0 ft	kg lb	*20 400 *44,200	17 700 38,100	*17 800 *38,600	13 950 30,000	*15 950 *34,650	11 250 24,200	*8850	*8850	*8450 *18,550	*8450 *18,550	13.55 44.46
1.5 m 5.0 ft	kg lb	*21 750 *47,100	16 900 36,350	*18 650 *40,450	13 450 28,900	16 350 35,150	10 950 23,500			*8900 *19,600	*8900 *19,600	13.49 44.26
0 m 0 ft	kg lb	*22 700 *49,100	16 250 34,950	*19 200 *41,600	13 000 27,950	16 050 34,550	10 650 22,900			*9600 *21,100	9150 20,200	13.26 43.50
-1.5 m -5.0 ft	kg lb	*23 000 *49,750	15 800 34,000	19 300 41,500	12 700 27,300	15 850 34,150	10 500 22,550			*10 550 *23,300	9500 21,000	12.84 42.13
-3.0 m -10.0 ft	kg lb	*22 550 *48,750	15 600 33,550	*18 800 *40,500	12 550 27,000	*15 350 *27,050	10 450 22,550			*12 050 *26,600	10 200 22,500	12.23 40.12
-4.5 m -15.0 ft	kg lb	*21 150 *45,450	15 550 33,550	*17 250 *36,800	12 600 27,200					*14 300 *31,850	11 350 25,150	11.39 37.37
-6.0 m -20.0 ft	kg lb	*18 250 *38,650	15 850 34,200							*14 450 *31,700	13 350 29,800	10.25 33.63
-7.5 m -25.0 ft	kg lb									*13 200 *28,700	*13 200 *28,700	8.71 28.58



ISO 10567



*Indicates that the load is limited by hydraulic lifting capacity rather than tipping load. The above loads are in compliance with hydraulic excavator lift capacity standard ISO 10567:2007. They do not exceed 87% of hydraulic lifting capacity or 75% of tipping load. Weight of all lifting accessories must be deducted from the above lifting capacities. Lifting capacities are based on the machine standing on a firm, uniform supporting surface. The use of a work tool attachment point to handle/lift objects, could affect the machine lift performance.

Lift capacity stays with ±5% for all available track shoes.

Always refer to the appropriate Operation and Maintenance Manual for specific product information.

390F L Hydraulic Excavator Specifications

General Purpose Boom Lift Capacities – Counterweight: 12.4 mt (27,337 lb) – without Bucket

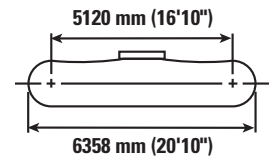
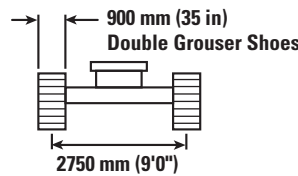
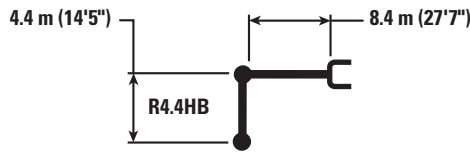

		3.0 m/10.0 ft		4.5 m/15.0 ft		6.0 m/20.0 ft		7.5 m/25.0 ft		9.0 m/30.0 ft		10.5 m/35.0 ft		12.0 m/40.0 ft		m ft			
10.5 m	kg									*15 400	*15 400					*11 350	*11 350	9.80	
35.0 ft	lb									*31,750	*31,750					*25,200	*25,200	32.15	
9.0 m	kg									*17 300	*17 300	*13 350	*13 350			*10 900	*10 900	10.83	
30.0 ft	lb									*37,850	*37,850	*29,550	*29,550			*24,050	*24,050	35.53	
7.5 m	kg									*18 000	*18 000	*16 850	15 150			*10 700	*10 700	11.58	
25.0 ft	lb									*39,250	*39,250	*35,700	32,500			*23,600	*23,600	37.99	
6.0 m	kg							*21 850	*21 850	*19 200	18 950	*17 450	14 800	*11 750	11 750	*10 750	*10 750	12.09	
20.0 ft	lb							*47,250	*47,250	*41,650	40,850	*37,950	31,750			*23,700	*23,700	39.67	
4.5 m	kg					*30 400	*30 400	*24 200	23 950	*20 600	18 200	*18 200	14 350	*15 150	11 550	*11 050	10 900	12.40	
15.0 ft	lb					*65,400	*65,400	*52,300	51,700	*44,600	39,200	*39,550	30,850	*29,200	24,700	*24,250	24,050	40.68	
3.0 m	kg					*34 100	31 350	*26 400	22 700	*21 900	17 450	*19 000	13 850	16 700	11 250	*11 500	10 500	12.52	
10.0 ft	lb					*73,500	67,650	*57,100	48,950	*47,500	37,550	*41,200	29,800	*34,000	24,200	*25,300	23,150	41.08	
1.5 m	kg					*36 200	29 850	*28 000	21 700	*22 950	16 750	*19 550	13 450	16 400	11 000	*12 200	10 400	12.46	
5.0 ft	lb					*78,200	64,300	*60,550	46,750	*49,700	36,150	*42,400	28,900	*35,200	23,700	*26,850	22,900	40.88	
0 m	kg					*36 500	29 050	*28 650	21 050	*23 450	16 300	19 700	13 100	16 250	10 850	*13 300	10 600	12.21	
0 ft	lb					*79,150	62,550	*62,000	45,300	*50,750	35,100	42,400	28,250	*29,700	23,350	*29,250	23,300	40.06	
-1.5 m	kg					*24 050	*24 050	*35 450	28 750	*28 300	20 700	*23 200	16 000	*19 400	12 950		*14 850	11 100	11.76
-5.0 ft	lb					*54,750	*54,750	*76,900	61,850	*61,250	44,550	*50,200	34,500	*41,850	27,850		*32,800	24,500	38.58
-3.0 m	kg	*23 500	*23 500	*33 450	*33 450	*33 200	28 850	*26 850	20 600	*22 050	15 950	*18 050	12 950			*16 450	12 100	11.08	
-10.0 ft	lb	*52,850	*52,850	*76,050	*76,050	*71,900	62,000	*58,100	44,400	*47,600	34,350	*38,650	27,900			*36,200	26,700	36.35	
-4.5 m	kg	*33 150	*33 150	*36 200	*36 200	*29 500	29 150	*24 150	20 800	*19 600	16 100					*16 050	13 800	10.14	
-15.0 ft	lb	*74,750	*74,750	*78,300	*78,300	*63,750	62,750	*51,950	44,850	*41,900	34,800					*35,300	30,650	33.27	
-6.0 m	kg			*28 650	*28 650	*23 900	*23 900	*19 400	*19 400							*14 950	*14 950	8.84	
-20.0 ft	lb			*61,400	*61,400	*51,050	*51,050	*41,050	*41,050							*32,650	*32,650	29.00	



ISO 10567



*Indicates that the load is limited by hydraulic lifting capacity rather than tipping load. The above loads are in compliance with hydraulic excavator lift capacity standard ISO 10567:2007. They do not exceed 87% of hydraulic lifting capacity or 75% of tipping load. Weight of all lifting accessories must be deducted from the above lifting capacities. Lifting capacities are based on the machine standing on a firm, uniform supporting surface. The use of a work tool attachment point to handle/lift objects, could affect the machine lift performance.

Lift capacity stays with ±5% for all available track shoes.

Always refer to the appropriate Operation and Maintenance Manual for specific product information.

390F L Hydraulic Excavator Specifications

General Purpose Boom Lift Capacities – Counterweight: 12.4 mt (27,337 lb) – without Bucket

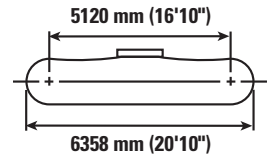
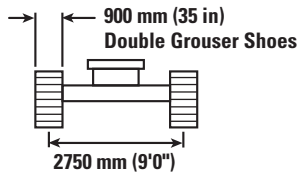
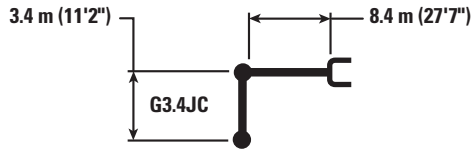

		4.5 m/15.0 ft		6.0 m/20.0 ft		7.5 m/25.0 ft		9.0 m/30.0 ft		10.5 m/35.0 ft		m ft		
10.5 m	kg											*15 450	*15 450	8.74
35.0 ft	lb											*34,350	*34,350	28.67
9.0 m	kg							*18 750	*18 750			*14 500	*14 500	9.89
30.0 ft	lb							*41,150	41,000			*32,100	*32,100	32.45
7.5 m	kg					*21 450	*21 450	*19 250	18 750	*17 150	14 350	*14 100	13 850	10.71
25.0 ft	lb					*46,450	*46,450	*41,900	40,350			*31,100	30,800	35.14
6.0 m	kg			*28 700	*28 700	*23 350	*23 350	*20 200	18 150	*18 250	14 100	*14 050	12 500	11.26
20.0 ft	lb			*61,750	*61,750	*50,500	*50,500	*43,850	39,050	*39,750	30,300	*30,900	27,650	36.94
4.5 m	kg			*32 800	31 700	*25 500	22 850	*21 400	17 450	*18 800	13 750	*14 250	11 650	11.59
15.0 ft	lb			*70,500	68,500	*55,050	49,350	*46,350	37,550	*40,800	29,500	*31,400	25,750	38.02
3.0 m	kg					*27 300	21 750	*22 450	16 750	*19 300	13 350	*14 800	11 250	11.72
10.0 ft	lb					*58,950	46,900	*48,600	36,100	*41,850	28,700	*32,550	24,800	38.45
1.5 m	kg					*28 250	20 950	*23 100	16 200	*19 550	13 000	*15 650	11 150	11.65
5.0 ft	lb			*64,950	62,150	*61,150	45,150	*50,000	34,900	42,150	27,950	*34,500	24,600	38.22
0 m	kg			*33 250	28 550	*28 200	20 500	*23 100	15 850	*19 350	12 800	*17 050	11 450	11.38
0 ft	lb			*76,750	61,350	*61,150	44,150	*50,050	34,150	41,700	27,500	*37,500	25,200	37.34
-1.5 m	kg	*21 450	*21 450	*33 300	28 550	*27 150	20 350	*22 300	15 700	*18 250	12 750	*17 050	12 150	10.90
-5.0 ft	lb	*49,500	*49,500	*72,400	61,350	*58,800	43,850	*48,200	33,850	*39,100	27,500	*37,600	26,800	35.76
-3.0 m	kg	*35 400	*35 400	*30 150	28 800	*24 900	20 500	*20 350	15 800			*16 600	13 500	10.71
-10.0 ft	lb	*77,250	*77,250	*65,400	61,900	*53,800	44,100	*43,650	34,100			*36,500	29,900	35.14
-4.5 m	kg	*29 450	*29 450	*25 450	*25 450	*21 000	20 900	*16 050	*16 050			*15 500	*15 500	9.13
-15.0 ft	lb	*63,800	*63,800	*54,800	*54,800	*45,000	*45,000					*33,900	*33,900	29.95
-6.0 m	kg			*18 000	*18 000	*13 500	*13 500					*13 000	*13 000	7.61
-20.0 ft	lb			*37,850	*37,850							*30,250	*30,250	24.97



ISO 10567



*Indicates that the load is limited by hydraulic lifting capacity rather than tipping load. The above loads are in compliance with hydraulic excavator lift capacity standard ISO 10567:2007. They do not exceed 87% of hydraulic lifting capacity or 75% of tipping load. Weight of all lifting accessories must be deducted from the above lifting capacities. Lifting capacities are based on the machine standing on a firm, uniform supporting surface. The use of a work tool attachment point to handle/lift objects, could affect the machine lift performance.

Lift capacity stays with ±5% for all available track shoes.

Always refer to the appropriate Operation and Maintenance Manual for specific product information.

390F L Hydraulic Excavator Specifications

General Purpose Boom Lift Capacities – Counterweight: 12.4 mt (27,337 lb) – without Bucket

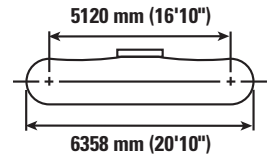
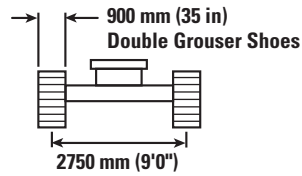
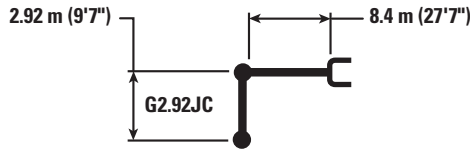

		4.5 m/15.0 ft		6.0 m/20.0 ft		7.5 m/25.0 ft		9.0 m/30.0 ft		10.5 m/35.0 ft		m ft		
10.5 m	kg					*21 250	*21 250					*18 700	*18 700	8.13
35.0 ft	lb					*47,000	*47,000					*41,650	*41,650	26.67
9.0 m	kg					*21 300	*21 300	*19 850	18 950			*17 500	*17 500	9.36
30.0 ft	lb					*46,500	*46,500	*43,050	40,550			*38,700	*38,700	30.71
7.5 m	kg					*22 500	*22 500	*20 150	18 650			*16 950	15 000	10.22
25.0 ft	lb					*48,850	*48,850	*43,900	40,150			*37,400	33,400	33.53
6.0 m	kg			*30 300	*30 300	*24 400	23 950	*21 000	18 100	*19 000	14 100	*16 900	13 450	10.80
20.0 ft	lb			*65,150	*65,150	*52,700	51,650	*45,650	38,950	*41,450	30,250	*37,200	29,750	35.43
4.5 m	kg					*26 400	22 750	*22 100	17 400	*19 350	13 800	*17 200	12 500	11.14
15.0 ft	lb					*57,050	49,050	*47,850	37,550	*42,100	29,600	*37,850	27,650	36.55
3.0 m	kg					*28 000	21 700	*23 000	16 800	*19 750	13 400	*17 850	12 050	11.28
10.0 ft	lb					*60,450	46,800	*49,800	36,200	*42,850	28,900	*39,300	26,600	37.01
1.5 m	kg					*28 650	21 000	*23 450	16 300	19 750	13 150	17 950	12 000	11.20
5.0 ft	lb					*62,000	45,300	*50,800	35,150	42,500	28,300	39,550	26,400	36.75
0 m	kg			*31 000	28 800	*28 250	20 650	*23 250	16 000	*19 350	13 000	*18 200	12 350	10.92
0 ft	lb			*74,100	61,900	*61,250	44,550	*50,300	34,550	*41,650	28,000	*40,100	27,150	35.83
-1.5 m	kg			*32 350	28 900	*26 800	20 600	*22 100	15 950			*17 900	13 200	10.42
-5.0 ft	lb			*70,400	62,150	*58,150	44,400	*47,750	34,400			*39,400	29,100	34.19
-3.0 m	kg	*32 300	*32 300	*28 850	*28 850	*24 150	20 800	*19 550	16 150			*17 200	14 800	9.65
-10.0 ft	lb	*70,700	*70,700	*62,600	*62,600	*52,150	44,850	*41,800	34,900			*37,850	32,800	31.66
-4.5 m	kg	*26 250	*26 250	*23 550	*23 550	*19 500	*19 500					*15 650	*15 650	8.55
-15.0 ft	lb	*56,950	*56,950	*50,750	*50,750	*41,500	*41,500					*34,250	*34,250	28.05



ISO 10567



*Indicates that the load is limited by hydraulic lifting capacity rather than tipping load. The above loads are in compliance with hydraulic excavator lift capacity standard ISO 10567:2007. They do not exceed 87% of hydraulic lifting capacity or 75% of tipping load. Weight of all lifting accessories must be deducted from the above lifting capacities. Lifting capacities are based on the machine standing on a firm, uniform supporting surface. The use of a work tool attachment point to handle/lift objects, could affect the machine lift performance.

Lift capacity stays with $\pm 5\%$ for all available track shoes.

Always refer to the appropriate Operation and Maintenance Manual for specific product information.

390F L Hydraulic Excavator Specifications

Mass Boom Lift Capacities – Counterweight: 12.4 mt (27,337 lb) – without Bucket

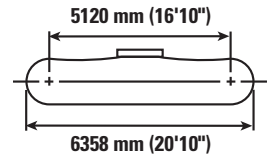
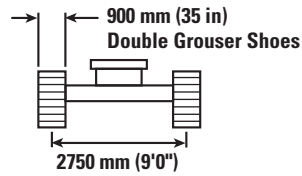
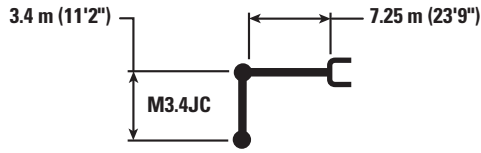

		3.0 m/10.0 ft		4.5 m/15.0 ft		6.0 m/20.0 ft		7.5 m/25.0 ft		9.0 m/30.0 ft		m ft		
10.5 m	kg											*17 250	*17 250	6.97
35.0 ft	lb											*38,550	*38,550	22.87
9.0 m	kg							*21 550	*21 550			*15 800	*15 800	8.38
30.0 ft	lb							*45,550	*45,550			*34,950	*34,950	27.49
7.5 m	kg							*23 200	*23 200	*18 850	18 800	*15 200	*15 200	9.33
25.0 ft	lb							*50,500	*50,500	*36,900	*36,900	*33,500	*33,500	30.61
6.0 m	kg					*29 000	*29 000	*24 600	*24 600	*21 850	18 450	*15 100	*15 100	9.66
20.0 ft	lb					*62,650	*62,650	*53,350	*53,350	*47,650	39,650	*33,250	*33,250	31.69
4.5 m	kg			*45 150	*45 150	*32 650	*32 650	*26 450	23 800	*22 700	17 900	*15 450	14 300	10.33
15.0 ft	lb			*96,800	*96,800	*70,500	*70,500	*57,250	51,300	*49,300	38,500	*33,950	31,550	33.89
3.0 m	kg					*35 800	31 750	*28 100	22 750	*23 500	17 300	*16 200	13 700	10.48
10.0 ft	lb					*77,300	68,450	*60,850	49,050	*50,950	37,250	*35,600	30,150	34.38
1.5 m	kg					*37 200	30 400	*29 050	21 900	*23 850	16 800	*17 450	13 600	10.40
5.0 ft	lb					*80,550	65,500	*62,950	47,200	*51,700	36,200	*38,350	29,950	34.12
0 m	kg			*27 900	*27 900	*36 650	29 750	*28 900	21 400	*23 450	16 500	*19 400	14 050	10.10
0 ft	lb			*64,500	*64,500	*79,450	64,000	*62,550	46,050	*50,650	35,500	*42,800	30,950	33.14
-1.5 m	kg	*23 500	*23 500	*41 650	*41 650	*34 200	29 600	*27 250	21 200	*21 650	16 400	*19 450	15 200	9.55
-5.0 ft	lb	*53,050	*53,050	*93,550	*93,550	*74,100	63,600	*58,850	45,650	*46,350	35,350	*42,850	33,500	31.33
-3.0 m	kg	*38 650	*38 650	*36 350	*36 350	*29 650	*29 650	*23 550	21 350			*18 450	17 450	8.70
-10.0 ft	lb	*87,350	*87,350	*78,900	*78,900	*64,050	*64,050	*50,500	46,050			*40,500	38,700	28.54
-4.5 m	kg			*26 650	*26 650	*22 050	*22 050					*15 900	*15 900	7.45
-15.0 ft	lb			*57,100	*57,100	*46,750	*46,750					*34,650	*34,650	24.44



ISO 10567



*Indicates that the load is limited by hydraulic lifting capacity rather than tipping load. The above loads are in compliance with hydraulic excavator lift capacity standard ISO 10567:2007. They do not exceed 87% of hydraulic lifting capacity or 75% of tipping load. Weight of all lifting accessories must be deducted from the above lifting capacities. Lifting capacities are based on the machine standing on a firm, uniform supporting surface. The use of a work tool attachment point to handle/lift objects, could affect the machine lift performance.

Lift capacity stays with ±5% for all available track shoes.

Always refer to the appropriate Operation and Maintenance Manual for specific product information.

390F L Hydraulic Excavator Specifications

Mass Boom Lift Capacities – Counterweight: 12.4 mt (27,337 lb) – without Bucket

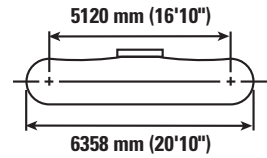
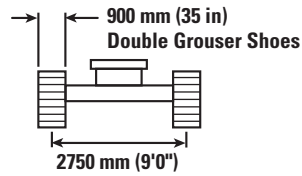
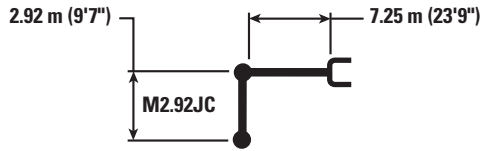

		3.0 m/10.0 ft		4.5 m/15.0 ft		6.0 m/20.0 ft		7.5 m/25.0 ft		9.0 m/30.0 ft		m ft		
10.5 m 35.0 ft	kg lb											*21 000	*21 000	6.29 20.64
9.0 m 30.0 ft	kg lb							*22 700 *44,500	*22 700 *44,500			*19 000 *42,100	*19 000 *42,100	7.82 25.66
7.5 m 25.0 ft	kg lb							*24 400 *53,150	*24 400 *53,150			*18 200 *40,200	*18 200 *40,200	8.83 28.97
6.0 m 20.0 ft	kg lb			*39 800 *85,250	*39 800 *85,250	*30 550 *65,950	*30 550 *65,950	*25 650 *55,700	24 650 53,100	*22 750 *49,600	18 350 39,400	*18 150 *39,900	16 700 37,100	9.50 31.17
4.5 m 15.0 ft	kg lb					*34 050 *73,400	33 250 71,750	*27 350 *59,200	23 650 50,950	*23 400 *50,800	17 850 38,400	*18 550 *40,850	15 350 33,900	9.89 32.45
3.0 m 10.0 ft	kg lb					*36 700 *79,300	31 450 67,800	*28 800 *62,300	22 650 48,850	*23 950 *52,000	17 300 37,300	*19 550 *42,950	14 700 32,350	10.04 32.94
1.5 m 5.0 ft	kg lb					*37 450 *81,200	30 350 65,300	*29 400 *63,650	21 900 47,200	*24 100 *52,100	16 900 36,350	*21 150 *46,550	14 600 32,150	9.96 32.68
0 m 0 ft	kg lb			*26 100 *60,800	*26 100 *60,800	*36 200 *78,600	29 850 64,200	*28 800 *62,300	21 500 46,300	*23 250 *50,100	16 650 35,850	*20 900 *46,100	15 150 33,400	9.64 31.63
-1.5 m -5.0 ft	kg lb	*54,900	*54,900	*40 200 *87,750	*40 200 *87,750	*33 100 *71,850	29 850 64,150	*26 600 *57,400	21 400 46,150	*20 550	16 700	*20 250 *44,600	16 550 36,500	9.06 29.72
-3.0 m -10.0 ft	kg lb			*33 150 *71,950	*33 150 *71,950	*27 850 *60,050	*27 850 *60,050	*21 950 *46,750	21 700 46,750			*18 800 *41,250	*18 800 *41,250	8.17 26.80
-4.5 m -15.0 ft	kg lb					*18 750 *39,200	*18 750 *39,200					*15 650 *36,400	*15 650 *36,400	6.74 22.11



ISO 10567



*Indicates that the load is limited by hydraulic lifting capacity rather than tipping load. The above loads are in compliance with hydraulic excavator lift capacity standard ISO 10567:2007. They do not exceed 87% of hydraulic lifting capacity or 75% of tipping load. Weight of all lifting accessories must be deducted from the above lifting capacities. Lifting capacities are based on the machine standing on a firm, uniform supporting surface. The use of a work tool attachment point to handle/lift objects, could affect the machine lift performance.

Lift capacity stays with $\pm 5\%$ for all available track shoes.

Always refer to the appropriate Operation and Maintenance Manual for specific product information.

390F L Hydraulic Excavator Specifications

Work Tool Offering Guide*

Boom Options	Reach Boom 10.0 m (32'10")			General Purpose Boom 8.4 m (27'7")			Mass Boom 7.25 m (23'9")	
Stick Options	R5.5 m (18'1") HD	R4.4 m (14'5") HD	R5.5 m (18'1") HD	R4.4 m (14'5") HD	G3.4 m (11'2") HD	G2.92 m (9'7") HD	M3.4 m (11'2")	M2.92 m (9'7")
Multi Processor	MP40 CC Jaw	MP40 CC Jaw	MP40 CC Jaw	MP40 CC Jaw				
	MP40 CR Jaw	MP40 CR Jaw	MP40 CR Jaw	MP40 CR Jaw				
		MP40 PS Jaw		MP40 PS Jaw				
	MP40 S Jaw	MP40 S Jaw	MP40 S Jaw	MP40 S Jaw				
Mobile Scrap and Demolition Shear		S365C		S365C	S385C	S385C	S385C	S385C
Rippers								
Pin Grabber Coupler								
Dedicated Quick Coupler								

These work tools are available for the 390F L.
Consult your Cat dealer for proper match.

*Matches are dependent on excavator configurations. Consult your Cat dealer for proper work tool match.

390F L Hydraulic Excavator Specifications

Bucket Specifications and Compatibility

	Linkage	Width		Capacity		Weight		Fill %	900 mm (35 in) Double Grouser 12.4 mt (27,337 lb) Counterweight									
		mm	in	m ³	yd ³	kg	lb		General Purpose Boom				Reach Boom		Mass Boom			
									G2.92 m (9'7")	G3.4 m (11'2")	R4.4 m (14'5")	R5.5 m (18'1")	R4.4 m (14'5")	R5.5 m (18'1")	M2.92 m (9'7")	M3.4 m (11'2")		
Without Quick Coupler																		
General Duty (GD)																		
	HB2	1350	54	3.00	4.00	3406	7,507	100			●	⊙	⊖	◇				
	HB2	1650	66	3.90	5.10	3794	8,362	100			⊙	○	◇	⊗				
	HB2	1900	75	4.60	6.00	4155	9,158	100			⊖	◇	⊗	⊗				
	HB2	1100	43	2.20	2.80	2856	6,295	100			●	●	●	⊙				
	HB2	1350	54	2.90	3.80	3187	7,024	100			●	●	⊖	○				
	HB2	1650	66	3.70	4.90	3650	8,045	100			⊙	⊖	○	⊗				
	HB2	1900	75	4.30	5.70	3923	8,646	100			⊖	X	◇	X				
	HB2	2000	79	4.60	6.00	4032	8,887	100			X	X	X	X				
	JC	2300	91	5.70	7.40	5822	12,832	100	○	◇					⊙	⊖		
	JC	2420	95	6.00	7.90	6004	13,233	100	○	◇					⊖	⊖		
	JC	2575	101	6.50	8.50	6238	13,749	100	◇	◇					⊖	○		
General Duty XL (GDXL)																		
	HB2	2000	79	5.30	7.00	4400	9,698	100			○	◇	⊗	⊗				
	HB2	2200	87	6.00	8.00	4796	10,570	100			X	X	X	X				
Heavy Duty (HD)																		
	JC	1750	69	4.10	5.30	4799	10,577	100	⊙	⊙					●	●		
	JC	2090	82	5.10	6.60	5441	11,992	100	⊖	○					●	⊙		
	JC	2300	91	5.70	7.40	5892	12,986	100	○	◇					⊙	⊖		
Severe Duty (SD)																		
	HB2	1100	43	2.30	3.00	3282	7,234	90			●	●	●	⊖				
	HB2	1350	54	3.00	4.00	3736	8,234	90			●	●	⊖	◇				
	HB2	1650	66	3.90	5.10	4163	9,175	90			⊙	⊖	◇	⊗				
	HB2	1900	75	4.60	6.00	4553	10,035	90			⊖	◇	⊗	⊗				
	JC	1960	77	4.60	6.00	6229	13,729	90	⊖	○					●	●		
Severe Duty (SDV)																		
	JC	2200	87	5.40	7.00	6809	15,007	90	○	◇					⊙	⊖		
	JC	2350	93	5.40	7.60	7015	15,462	90	○	◇					⊙	⊖		
Extreme Duty (XDV)																		
	JC	2200	87	5.00	6.50	7411	16,334	90	○	◇					⊙	⊖		
	JC	2350	93	5.40	7.10	7758	17,099	90	◇	◇					⊙	⊖		
	JC	2500	98	5.70	7.50	7993	17,617	90	◇	⊗					⊖	○		
Extreme Duty Granite (XDG)																		
	JC	2090	82	5.00	6.50	7729	17,035	90	○	◇					⊙	⊖		
	JC	2090	82	5.00	6.50	7826	17,249	90	○	◇					⊙	⊖		
Maximum load pin-on (payload + bucket)									kg	13 319	12 250	11 094	9464	8121	6881	16 797	15 454	
									lb	29,355	26,998	24,451	20,858	17,898	15,166	37,020	34,061	
With Quick Coupler (CW-70)																		
Severe Duty (SD)																		
	JC	2150	85	5.40	7.10	6243	13,760	90	○	◇					⊙	⊖		
	JC	2300	90	5.40	7.10	6556	14,449	90	◇	⊗					⊙	⊖		
Extreme Duty (XDV)																		
	JC	2350	93	5.40	7.10	7881	17,370	90	⊗	⊗					⊖	○		
Maximum load pin-on (payload + bucket)									kg	11 732	10 637	9879	8175	6785	5500	15 324	13 930	
									lb	25,858	23,443	21,772	18,017	14,953	12,122	33,774	30,702	

Maximum Material Density:

● 2100 kg/m³ (3,500 lb/yd³)

⊙ 1800 kg/m³ (3,000 lb/yd³)

⊖ 1500 kg/m³ (2,500 lb/yd³)

○ 1200 kg/m³ (2,000 lb/yd³)

◇ 900 kg/m³ (1,500 lb/yd³)

⊗ Not recommended

X Not allowed per bucket durability guide

The above loads are in compliance with hydraulic excavator standard EN474, they do not exceed 87% of hydraulic lifting capacity or 75% of tipping capacity with front linkage fully extended at ground line with bucket curled.

Capacity based on ISO 7451.

Bucket weight with long tips.

Caterpillar recommends using appropriate work tools to maximize the value customers receive from our products. Use of work tools, including buckets, which are outside of Caterpillar's recommendations or specifications for weight, dimensions, flows, pressures, etc. may result in less-than-optimal performance, including but not limited to reductions in production, stability, reliability, and component durability. Improper use of a work tool resulting in sweeping, prying, twisting and/or catching of heavy loads will reduce the life of the boom and stick.

390F L Standard Equipment

Standard Equipment

Standard equipment may vary. Consult your Cat dealer for details.

CAB

- Parallel wiper and washer
- Mirrors
- Pressurized operator station with positive filtration
- Laminated glass front upper window and tempered other windows
- Sliding upper door window (left-hand cab door)
- Removable lower windshield with in cab storage bracket
- Openable skylight
- Interior:
 - Glass-breaking safety hammer
 - Coat hook
 - Beverage holder
 - Literature holder
 - Interior lighting
 - Radio mounting
 - Two 12V stereo speakers
 - Storage shelf suitable for lunch or toolbox
 - Power supply with 12V, two power outlets (10 amp)
 - Thumb wheel modulation joystick for use with combined auxiliary control
 - Sun screen
 - Straight travel pedal
 - Air conditioner, heater and defroster with climate control
- Windshield:
 - 70-30 split, sliding
- Seat:
 - Adjustable high-back, heated and ventilated seat with air suspension
 - Seat belt, 51 mm (2 inch)
 - Adjustable armrest
 - Height adjustable joystick consoles
 - Neutral lever (lock out) for all controls
 - Travel control pedals with removable hand levers
 - Capability of installing two additional pedals
 - Two speed travel
 - Floor mat, washable

• Monitor:

- Clock
- Video ready
- Color LCD display with warning, filter/fluid change, and working hour information
- Language display (full graphic and full color display)
- Machine condition, error code and tool mode setting information
- Start-up level check for engine oil, engine coolant and hydraulic oil
- Warning, filter/fluid change and working hour information
- Fuel consumption meter
- Rearview camera

ELECTRICAL

- 80 amp alternator
- Circuit breaker
- Battery
- Travel alarm
- Beacon electrical outlet

ENGINE

- C18 ACERT diesel engine
- Meets Tier 4 Final emission standards
- 2300 m (7,500 ft) altitude capability with no derate
- Up to B20 biodiesel capable
- Automatic engine speed control
- Electric priming pump with switch
- Water separator in fuel line including water level sensor and indicator
- Economy and standard power modes
- Air cleaner
- Reversing cooling fan
- Steel wall between engine and pump compartment
- 4 micron fuel filter
- Quick drains, engine and hydraulic oil (QuickEvac)

HYDRAULIC SYSTEM

- Reverse swing dampening valve
- Automatic swing parking brake
- High-performance hydraulic return filter
- Regeneration circuit for boom and stick
- Capability of installing additional auxiliary circuits
- Reversing cooling fan
- Bio oil capable
- SmartBoom™

LIGHTS

- Cab and boom lights with time delay
- Exterior lights integrated into storage box

UNDERCARRIAGE/UPPERFRAME

- Grease Lubricated Track with PPR2 GLT4, resin seal
- Heavy duty track roller
- Heavy duty track motor guards
- Towing eye on base frame
- Heavy duty bottom guards on upperframe
- Counterweight with lifting eye
- Swivel guard

SAFETY AND SECURITY

- Cat one key security system
- Door locks
- Cap locks on fuel and hydraulic tanks
- Lockable external tool/storage box
- Signaling/warning horn
- Secondary engine shutoff switch
- Mirrors
- Rear window for emergency exit
- Rear vision camera
- Capability to connect a beacon
- Bolt on FOGS capability
- Service walkways
- Safety hammer for breaking cab glass

INTEGRATED TECHNOLOGIES

- Product Link
- Rearview camera

Optional Equipment

Optional equipment may vary. Consult your Cat dealer for details.

FRONT LINKAGE

- Reach boom (10.0 m/32'10"):
 - R5.5HB2 (18'1")
 - R4.4HB2 (14'5")
- General Purpose boom (8.4 m/27'7"):
 - R5.5HB2 (18'1")
 - R4.4HB2 (14'5")
 - G3.4JC (11'2")
 - G2.92JC (9'7")
- Mass boom (7.25 m/23'9"):
 - M3.4JC (11'2")
 - M2.9JC (9'7")
- JC-family bucket linkage (with lifting eye)
- HB2-family bucket linkage (with lifting eye)
- Cat Quick Coupler

TRACK

- 650 mm (26 in) double grouser heavy duty
- 750 mm (30 in) double grouser heavy duty
- 900 mm (35 in) double grouser heavy duty

COUNTERWEIGHT

- With removal device
- Fixed

ENGINE

- Fast fill port for fuel

GUARDS

- FOGS (Falling Object Guard System) including overhead and windshield guards
- Vandalism guards for windshield
- Track guiding guards:
 - Full length, two pieces
 - Segmented, three pieces

LIGHTS

- Boom working lights, halogen
- Boom working lights, HID

HYDRAULIC SYSTEM

- Boom and stick lowering control devices with SmartBoom
- Counterweight removal device
- HP hydraulic lines for boom and stick
- MP hydraulic lines for boom and stick
- QC hydraulic lines for boom and stick
- QC control

ELECTRICAL

- Cold weather starting package
- Electric refueling pump with auto shutoff
- Fast fill fuel system

CAT CONNECT TECHNOLOGIES

- Cat Production Measurement
- Cat Grade Control
- Cat AccuGrade

For more complete information on Cat products, dealer services, and industry solutions, visit us on the web at www.cat.com

© 2017 Caterpillar
All rights reserved

Materials and specifications are subject to change without notice. Featured machines in photos may include additional equipment. See your Cat dealer for available options.

CAT, CATERPILLAR, SAFETY.CAT.COM, their respective logos, "Caterpillar Yellow" and the "Power Edge" trade dress, as well as corporate and product identity used herein, are trademarks of Caterpillar and may not be used without permission.

VisionLink is a trademark of Trimble Navigation Limited, registered in the United States and in other countries.

AEHQ8028-01
Replaces AEHQ8028
(AmN)

